

Per Aspera ad Astra:

Impact of high precision standard model predictions for new physics searches

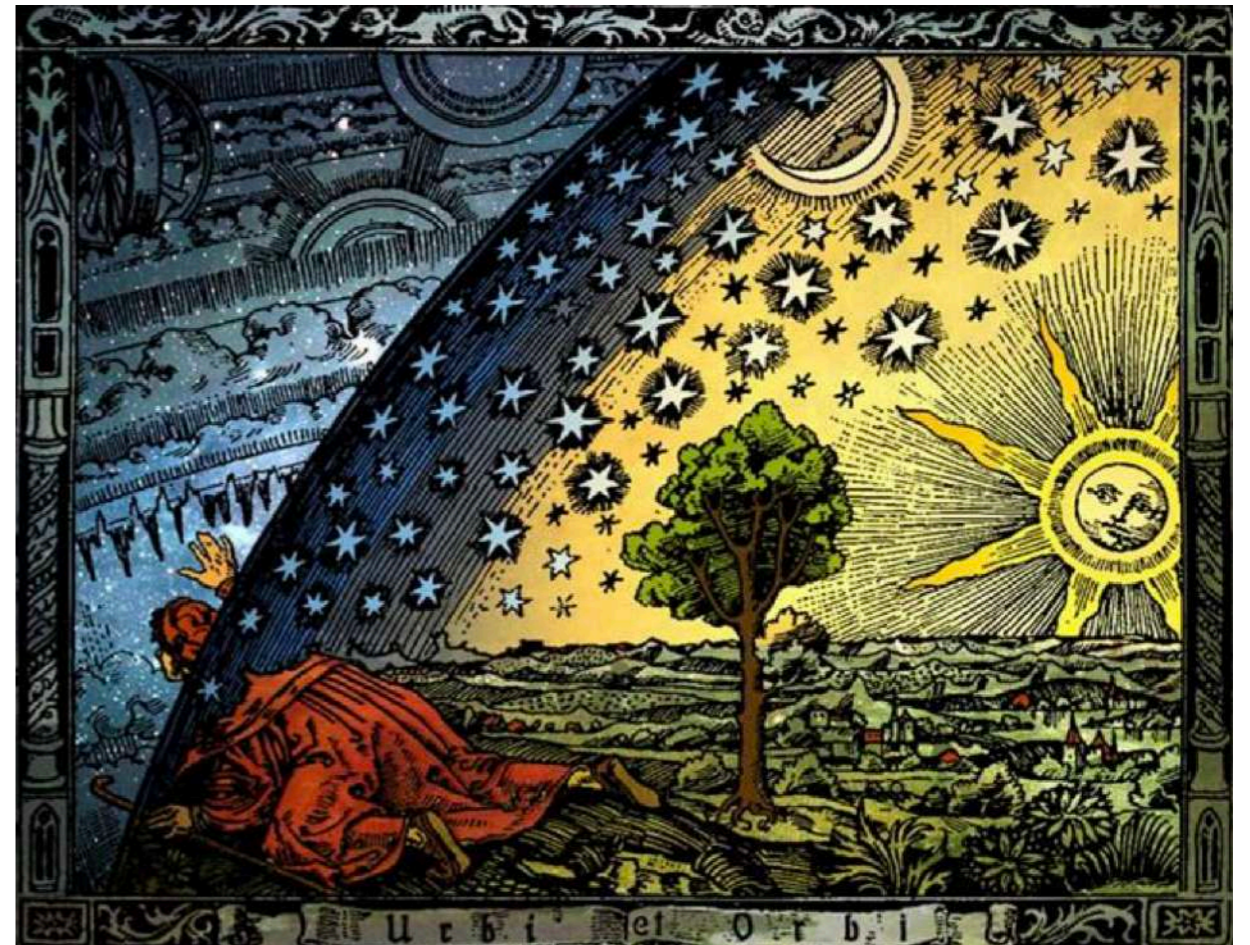
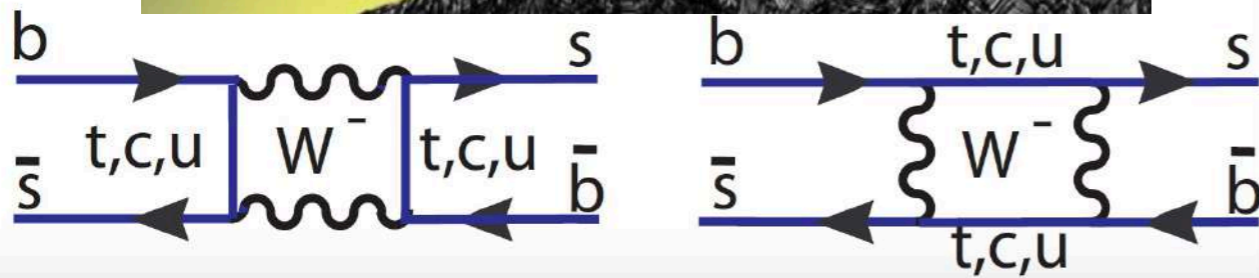
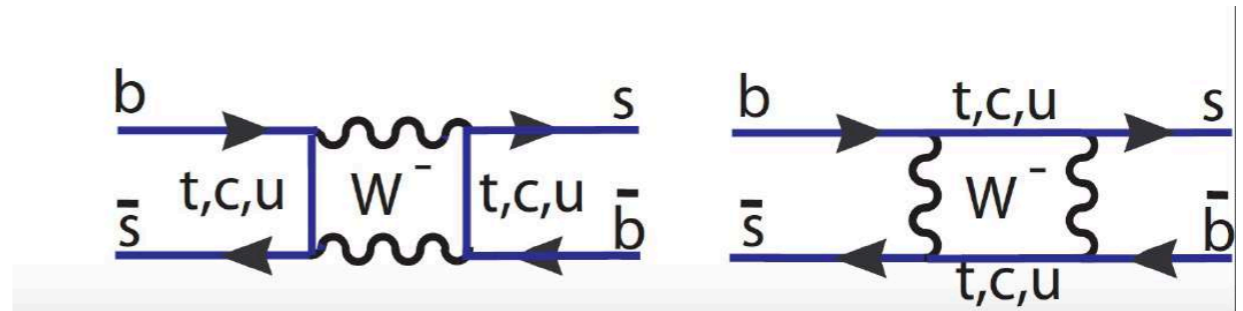

Alexander Lenz, IPPP Durham
Seminar, Cambridge University
28.11.2019

Messages from the machine room to the top deck

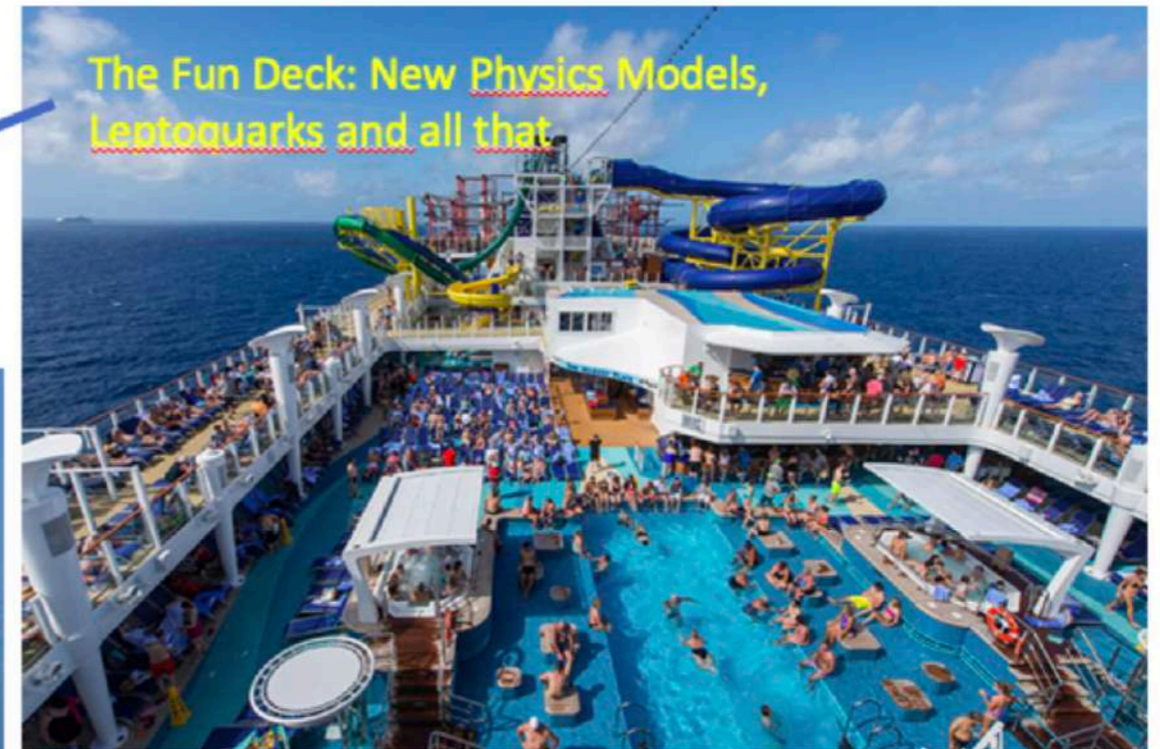

Outline

- **Motivation for Flavour Physics**
 - Understanding of QCD
 - Determination of SM parameter
 - CP violation
 - Search for new physics
- **Mass differences of neutral mesons**
 - Understanding of QCD
 - Determination of CKM parameter
 - Search for new physics
- **Decay rate difference/Lifetimes**
 - Understanding of QCD
 - Search for new physics
 - CP violation

Motivation for Flavour Physics

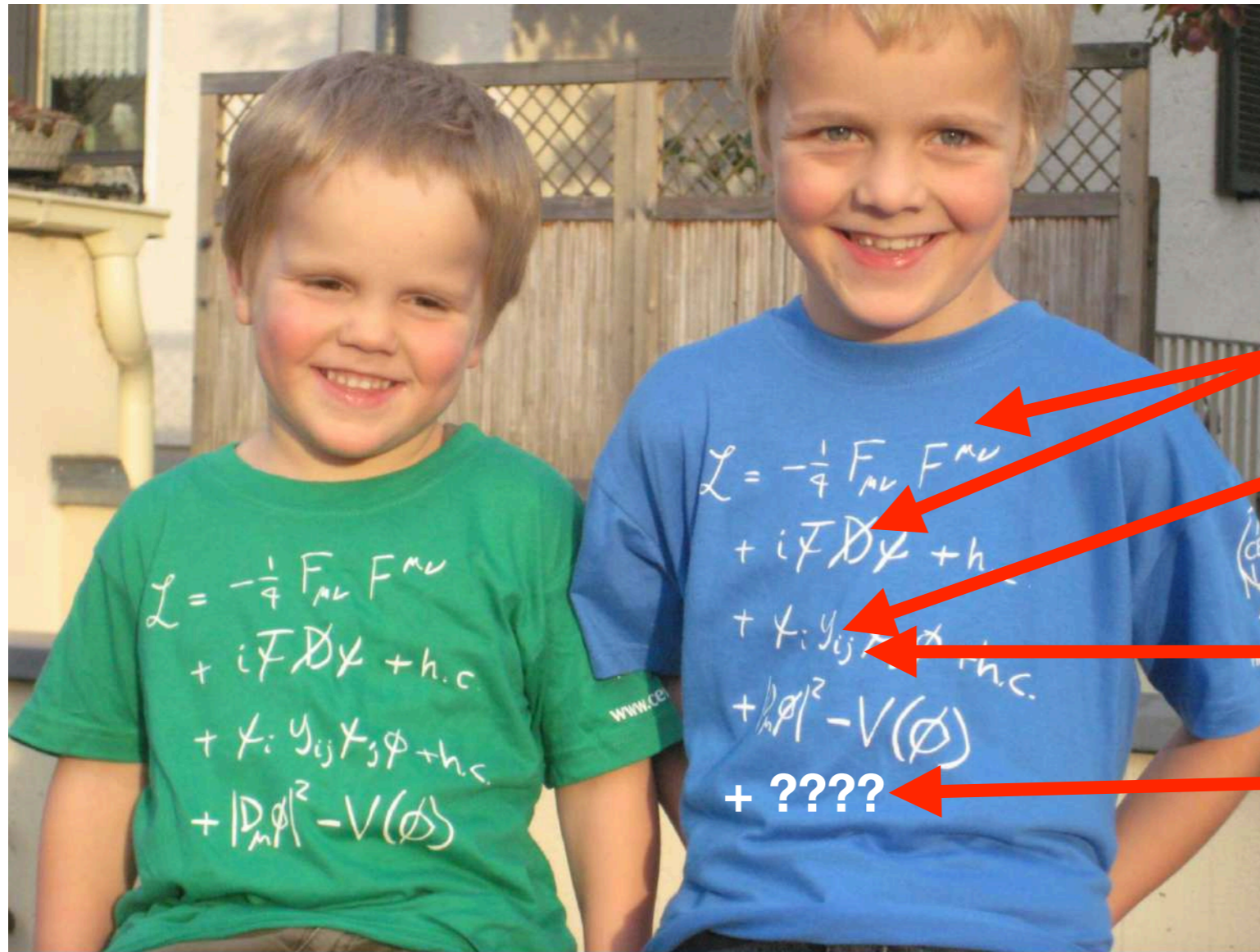

- Understanding of QCD
- Determination of SM parameter: CKM, quark masses,...
- CP violation
- Search for new physics

MOTIVATION FOR FLAVOUR PHYSICS

There are (at least) six kinds (=flavours) of quarks → BESSIII, LHCb,..

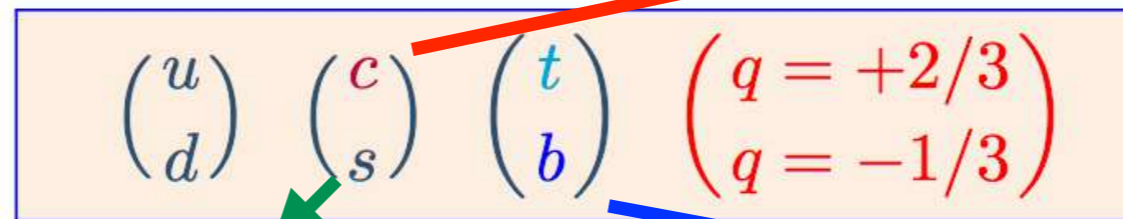

■ Proton $p = |uud\rangle$

NA62, KOTO...

BELLE II, LHCb,..

■ (Heavy) Flavour Physics describes hadrons with a **charm-** or a **bottom-quark**

	$D^0 = (\bar{u}c)$	$D^+ = (\bar{d}c)$	$D_s^+ = (\bar{s}c)$	$\Lambda_c = (udc)$
Mass (GeV)	1.86486	1.86962	1.96850	2.28646
Lifetime (ps)	0.4101	1.040	0.500	0.200

	$B_d = (\bar{b}d)$	$B^+ = (\bar{b}u)$	$B_s = (\bar{b}s)$	$B_c^+ = (\bar{b}c)$	$\Lambda_b = (udb)$
Mass (GeV)	5.27958	5.27926	5.3667	6.2745	5.6194
Lifetime(ps)	1.519	1.638	1.512	0.500	1.451

MOTIVATION FOR FLAVOUR PHYSICS

- Leptonic decays

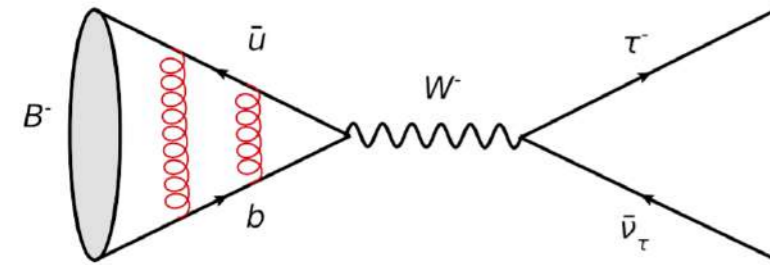

- Semi-Leptonic decays

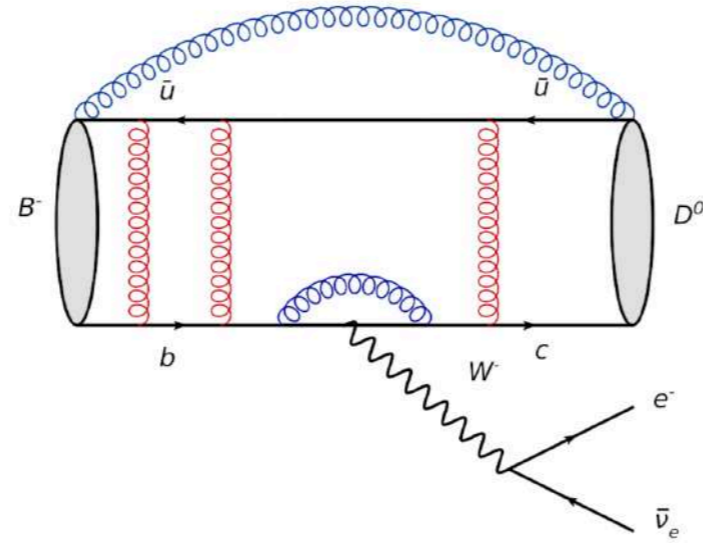

- Non-Leptonic decays

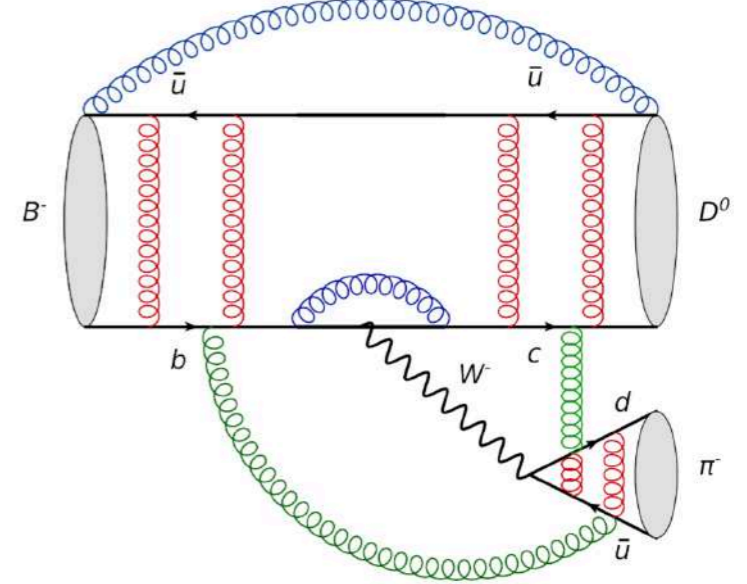

MOTIVATION FOR FLAVOUR PHYSICS

- Leptonic decays

- Semi-Leptonic decays

- Non-Leptonic decays

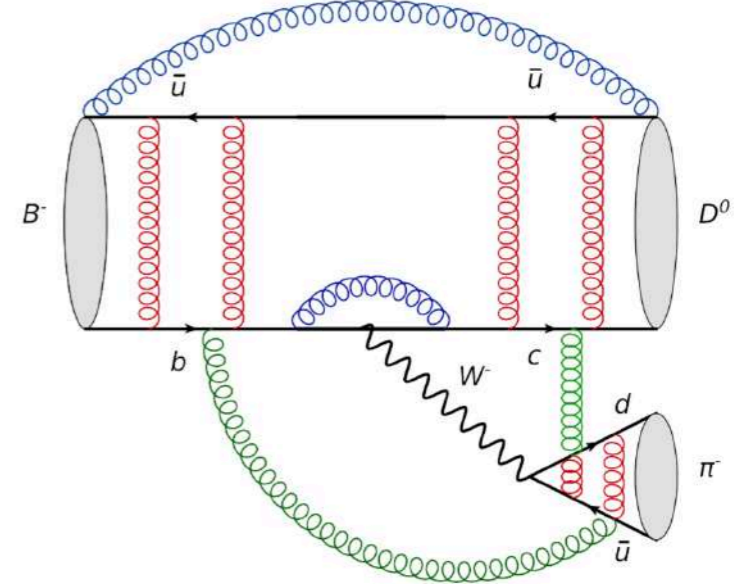
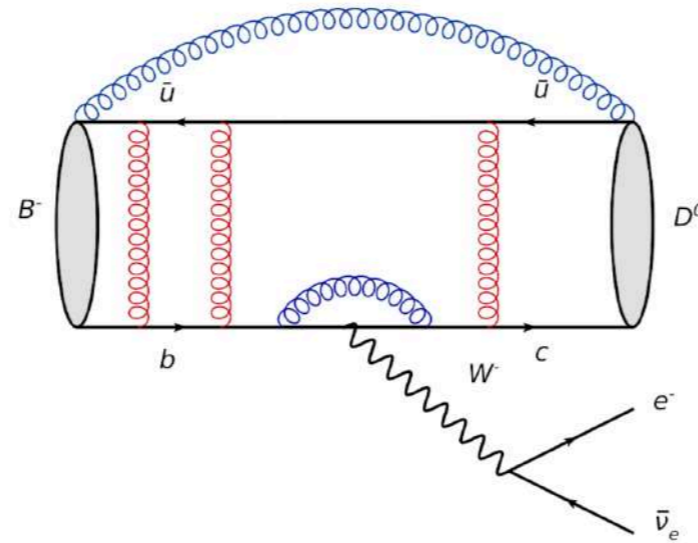
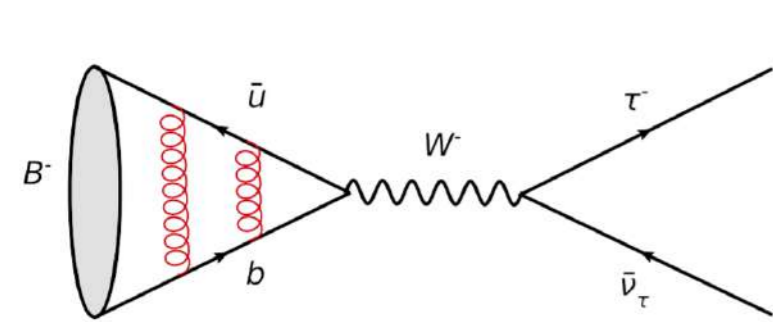

- Leptonic decays

- Semi-Leptonic decays

- Mixing

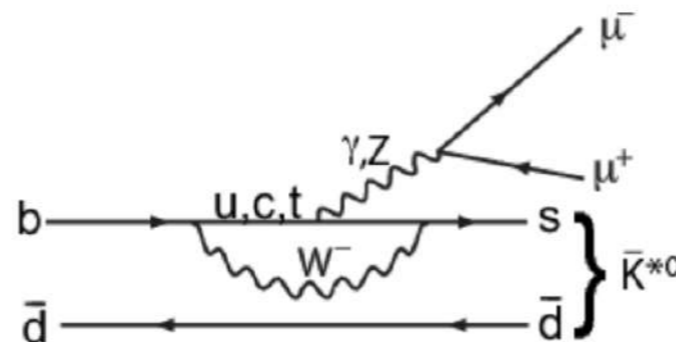
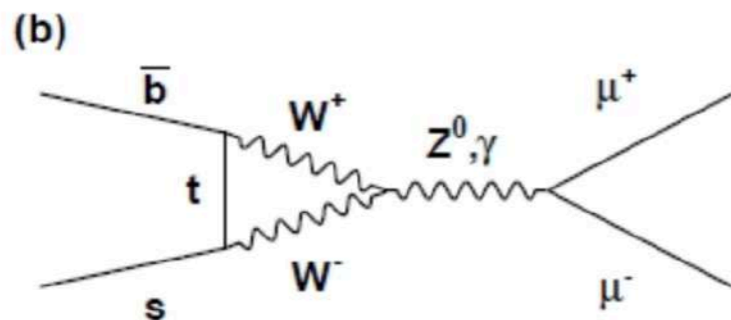
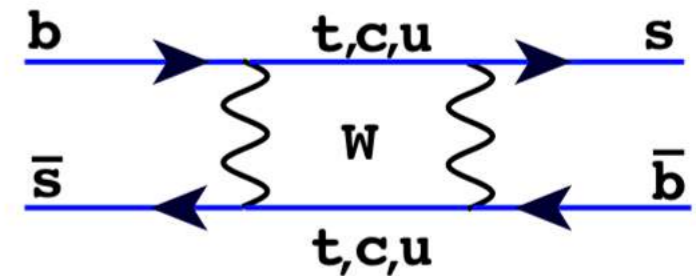
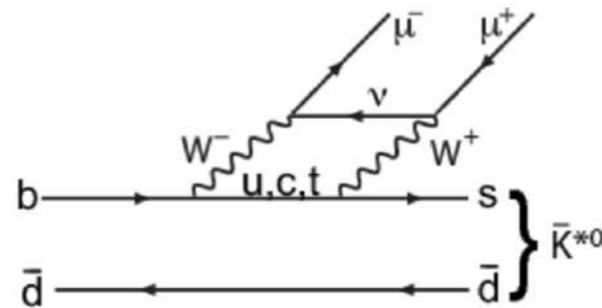
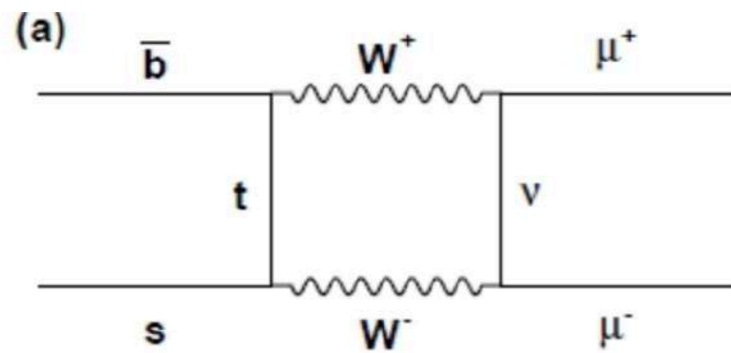

like $K \rightarrow \pi \nu \nu$

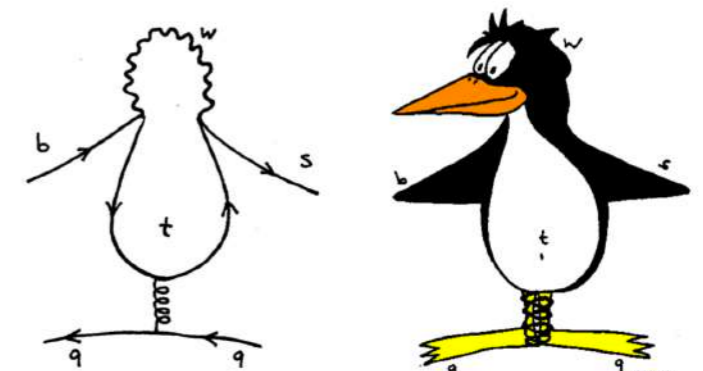

MOTIVATION FOR FLAVOUR PHYSICS

Baryon Asymmetry in the Universe:

A violation of the **CP symmetry** - which causes matter and anti-matter to evolve differently with time - seems to be necessary to explain the existence of matter in the Universe.

CP violation has so far only been found in hadron decays, which are experimentally investigated at LHCb and NA62 (CERN), SuperBelle (Japan),...

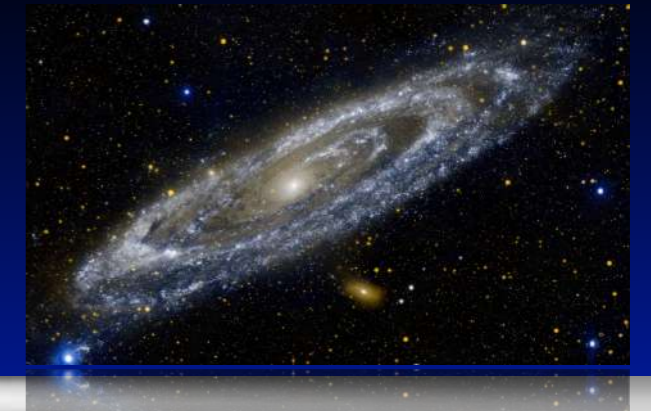

Indirect Search for BSM Physics:

To find hints for **Physics beyond the Standard Model** we can either use brute force (= higher energies) or more subtle strategies like high precision measurements.

New contributions to an observable f are identified via:

$$f^{\text{SM}} + f^{\text{NP}} = f^{\text{Exp}}$$

Understanding QCD:

Hadron decays are strongly affected by **QCD** (strong interactions) effects, which tend to overshadow the interesting fundamental decay dynamics. Theory tools like **effective theories, Heavy Quark Expansion, HQET, SCET, ...** enable a control over QCD-effects and they are used in other fields like Collider Physics, Higgs Physics, DM searches...

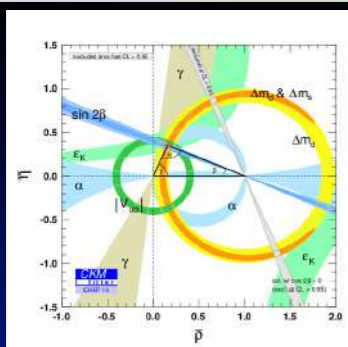
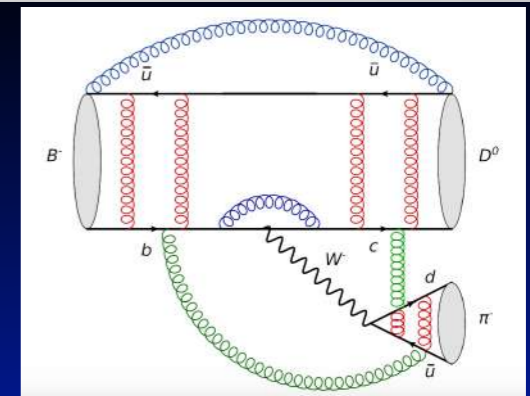

Standard Model parameters:

Hadron decays depend strongly on Standard Model parameters like **quark masses** and **CKM couplings** (which are the only known source of CP violation in the SM). A precise knowledge of these parameters is needed for all branches of particle physics.

MOTIVATION FOR FLAVOUR PHYSICS

• Leptonic decays

• Semi-Leptonic decays

• Non-Leptonic decays

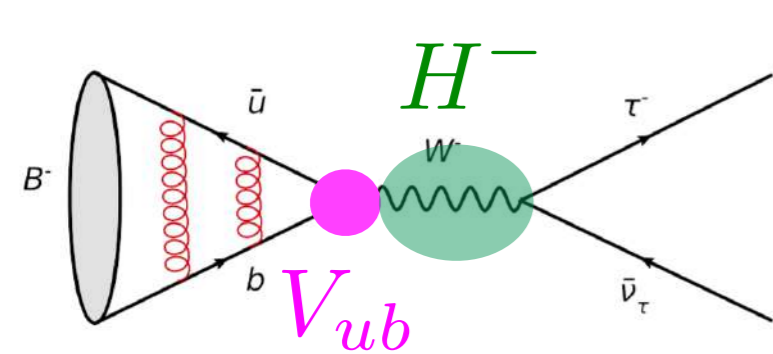

$$\langle 0 | \bar{b} \gamma^\mu \gamma_5 u | B_q(p) \rangle = i f_{B_q} p^\mu$$

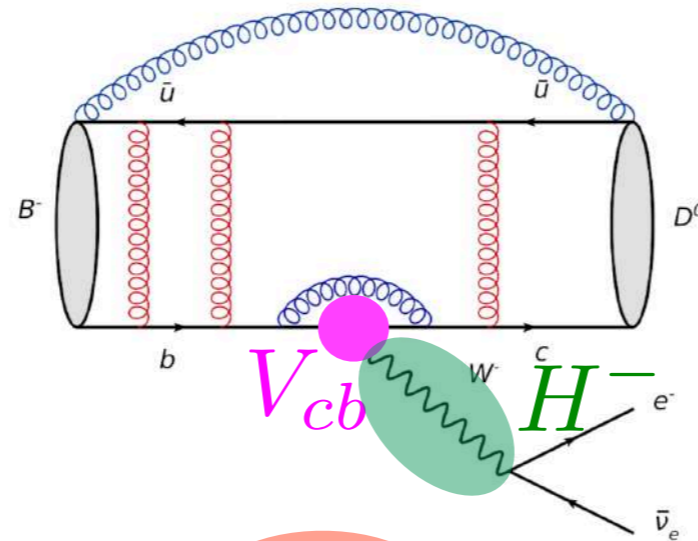

$$\langle D^0(p_D) | \bar{c} \gamma_\mu b | B^-(p_B) \rangle = f_+^{B^- \rightarrow D^0}(q^2) \left(p_B^\mu + p_D^\mu - \frac{m_B^2 - m_D^2}{q^2} q^\mu \right)$$

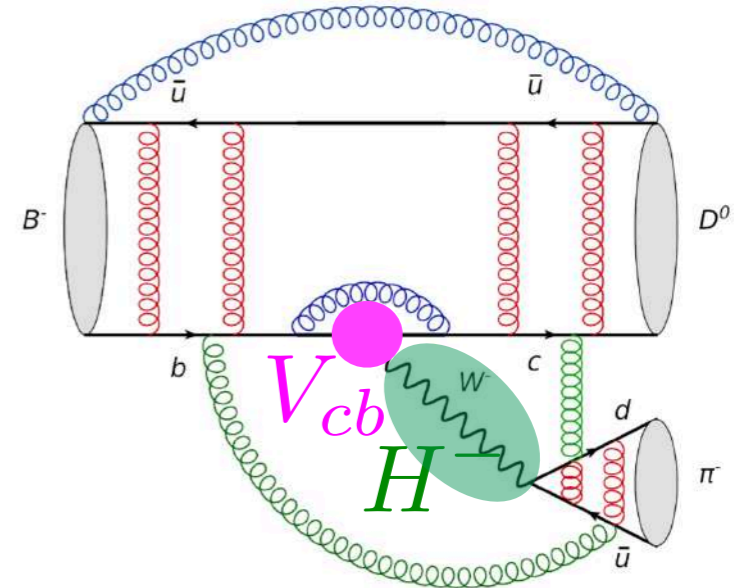

$$\langle D^0 \pi^- | \bar{c} \gamma_\mu (1 - \gamma_5) b \cdot \bar{u} \gamma^\mu (1 - \gamma_5) d | B^- \rangle \approx \langle D^0 | \bar{c} \gamma_\mu (1 - \gamma_5) b | B^- \rangle \cdot \langle \pi^- | \bar{u} \gamma^\mu (1 - \gamma_5) d | 0 \rangle$$

1. Imaginary part in CKM elements = CP violation

2. Instead of a W a charged Higgs H might be exchanged = BSM

3. QCD effects are crucial: decay constant, form factors,...

4. Determination of SM parameter

MOTIVATION FOR FLAVOUR PHYSICS

- Huge experimental progress: **B-factories, Tevatron, BESS III** and LHC (**ATLAS, CMS, LHCb**) and soon **Belle II**
- **LHCb**: >500 paper, >40k citations, >9fb⁻¹



MOTIVATION FOR FLAVOUR PHYSICS

➤ We have interesting anomalies!

σ

- 3-6: Semi-leptonic loop-level decays (small BSM)
- 3.x: Semi-leptonic tree-level decays (large BSM)
- 3.6: B-mixing phase (dimuon asymmetry)
- 3.5: Muon $g-2$
- 2.8: ?K-mixing/epsilon' (huge lattice progress)
- 2.6: Zbb coupling (LEP FB asym)
- 2.x: K-pi puzzle
- 2.x: tau to mu nu nu/tau to e nu nu
- 2.x: V_{us} : K vs. tau
- 2.x: V_{cb} , V_{ub} inclusive vs exclusive measurements

Outline

- **Motivation for Flavour Physics**
 - Understanding of QCD
 - Determination of SM parameter
 - CP violation
 - Search for new physics
- **Mass differences of neutral mesons**
 - Understanding of QCD
 - Determination of CKM parameter
 - Search for new physics
- **Decay rate difference/Lifetimes**
 - Understanding of QCD
 - Search for new physics
 - CP violation

B-MIXING

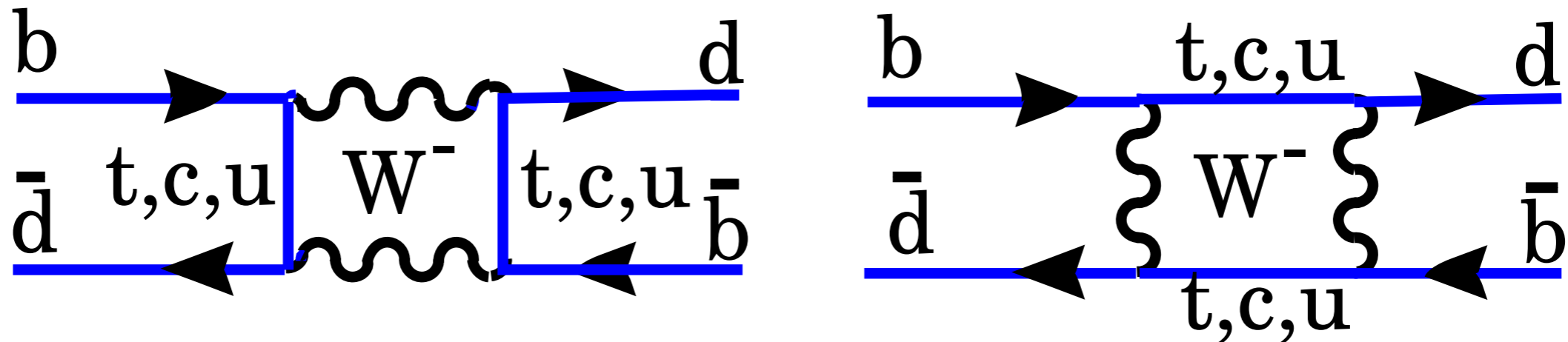

$|M_{12}|$, $|\Gamma_{12}|$ and $\phi = \arg(-M_{12}/\Gamma_{12})$ can be related to three observables:

- **Mass difference:** $\Delta M := M_H - M_L \approx 2|M_{12}|$ (off-shell)
 $|M_{12}|$: heavy internal particles: t, SUSY, ...
- **Decay rate difference:** $\Delta\Gamma := \Gamma_L - \Gamma_H \approx 2|\Gamma_{12}| \cos \phi$ (on-shell)
 $|\Gamma_{12}|$: light internal particles: u, c, ... (almost) no NP!!!
- **Flavor specific/semi-leptonic CP asymmetries:** e.g. $B_q \rightarrow X l \nu$ (semi-leptonic)

$$a_{sl} \equiv a_{fs} = \frac{\Gamma(\bar{B}_q(t) \rightarrow f) - \Gamma(B_q(t) \rightarrow \bar{f})}{\Gamma(\bar{B}_q(t) \rightarrow f) + \Gamma(B_q(t) \rightarrow \bar{f})} = \left| \frac{\Gamma_{12}}{M_{12}} \right| \sin \phi$$

Mass difference ΔM_q

Experiment.: HFLAV 2019

$$\Delta m_s = 17.757 \pm 0.021 \text{ ps}^{-1}$$

$$|\Delta m_d = 0.5064 \pm 0.0019 \text{ ps}^{-1}$$

Theory

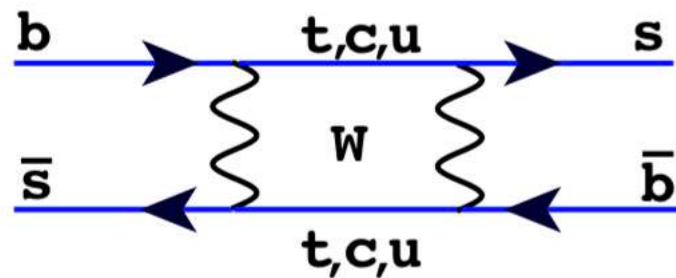

$$M_{12}^s = \frac{G_F^2}{12\pi^2} \lambda_t^2 M_W^2 S_0(x_t) B f_{B_s}^2 M_{B_s} \hat{\eta}_B$$

The equation is annotated with boxes and arrows:

- A blue box labeled "CKM" is around λ_t^2 .
- A white box labeled "Inami-Lim" is above $S_0(x_t)$ with a green arrow pointing to it.
- A red box is around $B f_{B_s}^2$.
- A white box labeled "Buras Jamin Weisz" is above $\hat{\eta}_B$ with a green arrow pointing to it.

In the SM one operator:

$$Q = \bar{s}^\alpha \gamma_\mu (1 - \gamma_5) b^\alpha \times \bar{s}^\beta \gamma^\mu (1 - \gamma_5) b^\beta$$

$$\langle Q \rangle \equiv \langle B_s^0 | Q | \bar{B}_s^0 \rangle = \frac{8}{3} M_{B_s}^2 f_{B_s}^2 B(\mu)$$

Non-perturbative theory input:

- 1) Lattice: ETM, FNAL-MILC, RBC-UKQCD, HPQCD
- 2) Sum rules: Siegen, Durham

Mass difference ΔM_q

Why is this interesting?

1. Interesting SM test per se - QCD/BSM
2. Determination of SM parameter
3. Many BSM models predict large effects in ΔM_q

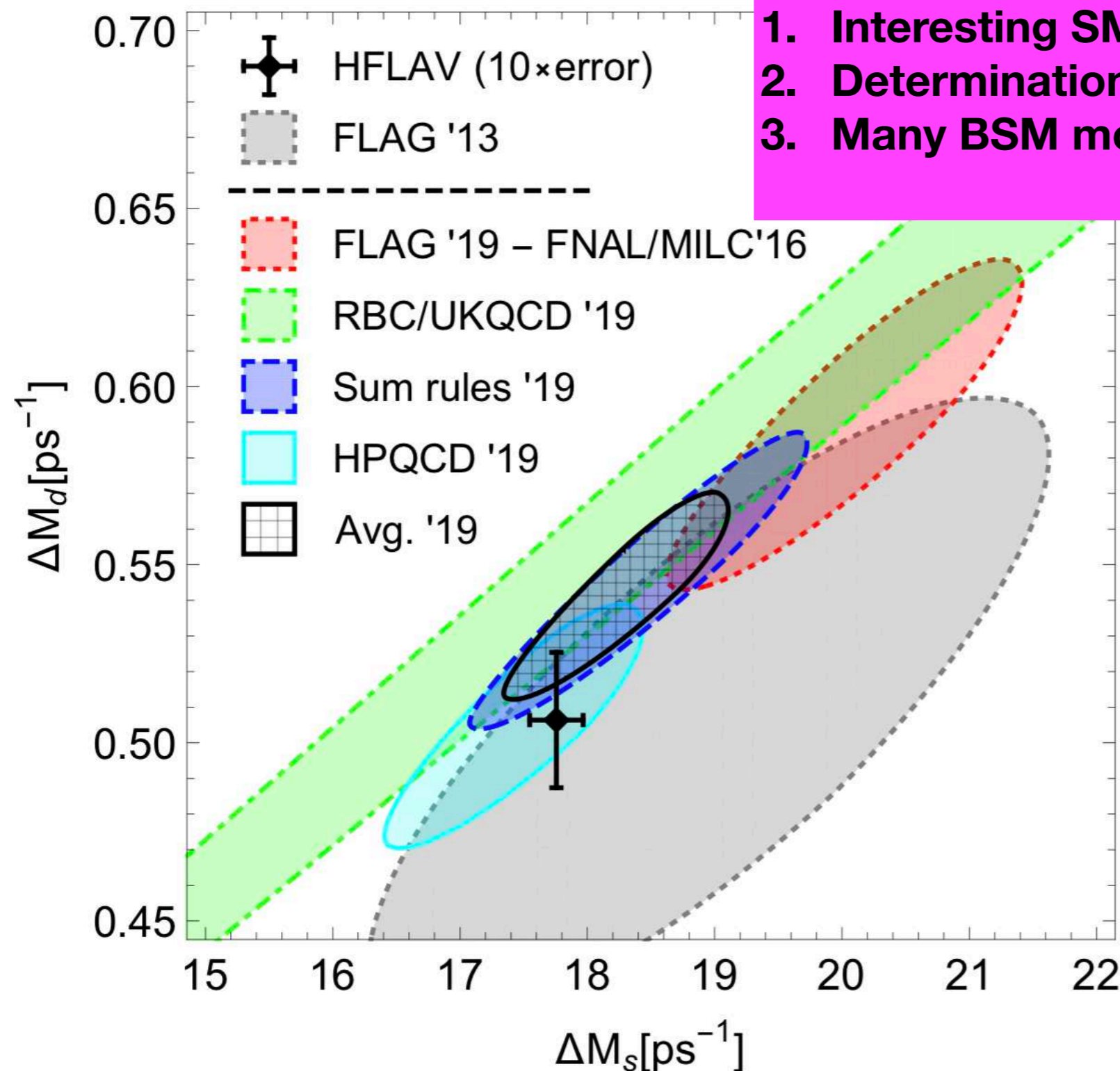

- Very active field:
- Flag 19: mostly FNAL-MILC (2/16)
 - RBC-UK: 12-18
 - Sum rules: Durham 4/19 (based on Siegen 16-18, Durham 17)
 - HPQCD: 07/19

New averages of lattice and sum rules
Di Luzio, Kirk, AL, Rauh
1909.11087 JHEP

Mass difference ΔM_q

ΔM_s^{SM}	This work	ABL 2015	LN 2011	LN 2006
Central Value	18.77 ps ⁻¹	18.3 ps ⁻¹	17.3 ps ⁻¹	19.3 ps ⁻¹
$\delta(f_{B_s} \sqrt{B_1})$	3.1%	13.9%	13.5%	34.1%
$\delta(V_{cb})$	3.4%	4.9%	3.4%	4.9%
$\delta(m_t)$	0.3%	0.7%	1.1%	1.8%
$\delta(\alpha_s)$	0.2%	0.1%	0.4%	2.0%
$\delta(\gamma)$	0.1%	0.1%	0.3%	1.0%
$\delta(V_{ub}/V_{cb})$	< 0.1%	0.1%	0.2%	0.5%
$\delta(\bar{m}_b)$	< 0.1%	< 0.1%	0.1%	— — —
$\sum \delta$	4.6%	14.8%	14.0%	34.6%

AL, 2019

Thanks to
Lattice,
Sum rules



Future scenario:
lattice/sum rule combined: +/- 2%
Vcb: +/- 1%
=> Uncertainty can be halved: +/- 2.2%

Mass difference - QCD

Mixing
Operators
Delta B = 2

$$\begin{array}{l}
 Q_1 = \bar{b}_i \gamma_\mu (1-\gamma_5) s_i \times \bar{b}_j \gamma^\mu (1-\gamma_5) s_j \\
 Q_2 = \bar{b}_i (1-\gamma_5) s_i \times \bar{b}_j (1-\gamma_5) s_j \\
 Q_3 = \bar{b}_i (1-\gamma_5) s_j \times \bar{b}_j (1-\gamma_5) s_i \\
 Q_4 = \bar{b}_i (1-\gamma_5) s_i \times \bar{b}_j (1+\gamma_5) s_j \\
 Q_5 = \bar{b}_i (1-\gamma_5) s_j \times \bar{b}_j (1+\gamma_5) s_i
 \end{array}
 \left. \vphantom{\begin{array}{l} Q_1 \\ Q_2 \\ Q_3 \\ Q_4 \\ Q_5 \end{array}} \right\} \Delta \Gamma_s^{\text{SM}}$$

$\Delta \Gamma_s^{\text{SM}}$
 $\&$
 $\Delta \Gamma_s^{\text{BSM}}$

Parameterisation
in terms of
decay constants
and
Bag parameter

$$\begin{array}{l}
 \langle B_s | Q_1 | \bar{B}_s \rangle = \frac{8}{3} \quad \Gamma_{B_s}^2 f_{B_s}^2 B_1 \\
 \langle B_s | Q_2 | \bar{B}_s \rangle = -\frac{5}{3} \left[\frac{\Gamma_{B_s}}{m_b + m_s} \right]^2 \quad \Gamma_{B_s}^2 f_{B_s}^2 B_2 \\
 \langle B_s | Q_3 | \bar{B}_s \rangle = \frac{1}{3} \left[\frac{\Gamma_{B_s}}{m_b + m_s} \right]^2 \quad \Gamma_{B_s}^2 f_{B_s}^2 B_3 \\
 \langle B_s | Q_4 | \bar{B}_s \rangle = \left(2 \left[\frac{\Gamma_{B_s}}{m_b + m_s} \right]^2 + \frac{1}{3} \right) \Gamma_{B_s}^2 f_{B_s}^2 B_4 \\
 \langle B_s | Q_5 | \bar{B}_s \rangle = \left(\frac{2}{3} \left[\frac{\Gamma_{B_s}}{m_b + m_s} \right]^2 + 1 \right) \Gamma_{B_s}^2 f_{B_s}^2 B_5
 \end{array}$$

• lattice • HQET-SR
• lattice

Mass difference - QCD

B_d-mixing

1. Lattice

- * ETM 1308.1851
- * FNAL-MILC 1602.03560
- * HPQCD 1907.01025

2. HQET-sum rules: 3-loop + part of NNLO matching:

- * Siegen: Grozin, Klein, Mannel, Pivovarov 1606.06054, 1706.05910, 1806.00253
- * Durham: Kirk (Rome), AL, Rauh (Bern) 1711.02100

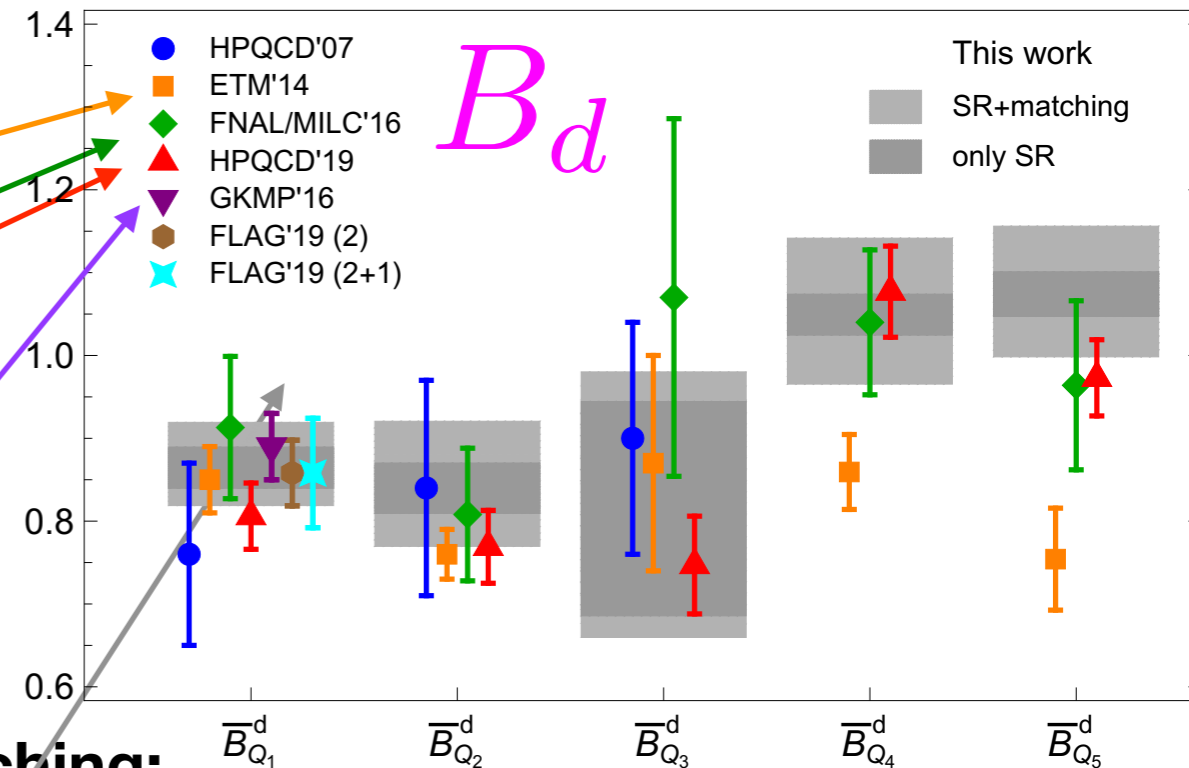

Three-loop HQET vertex diagrams for $B^0-\bar{B}^0$ mixing

Andrey G. Grozin and Roman N. Lee

arXiv:0812.4522v2

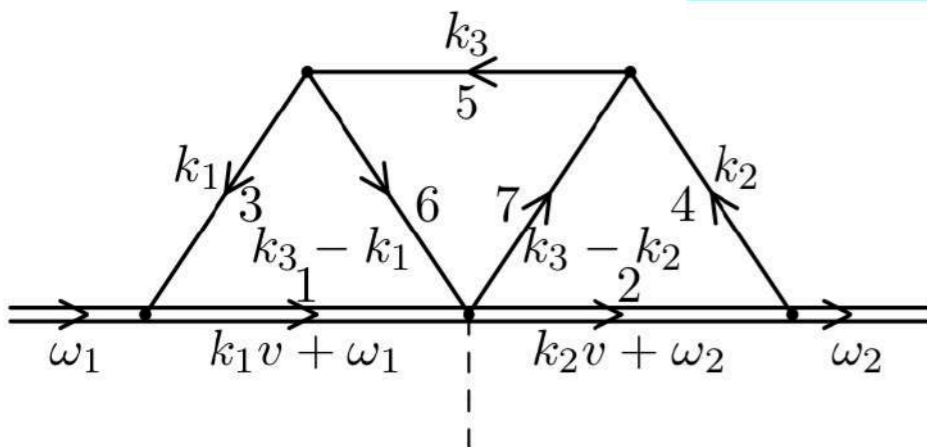

The various NLO contributions:

- ▶ Perturbative contribution (3-loop)

$$\Delta B_{PT} = -0.10 \pm 0.02 \pm 0.03$$

A. Grozin, R. Klein, ThM, AAP, Phys. Rev. D94, 034024 (2016)

- ▶ Quark condensate contribution (2-loop)

$$\Delta B_q = -0.002 \pm 0.001$$

A. Grozin, R. Klein, ThM, AAP, Phys. Rev. D94, 034024 (2016)

- ▶ Other condensates (tree-level+2-loop gluon cond)

$$\Delta B_{nonPT} = -0.006 \pm 0.005$$

ThM, B.D. Pecjak, AAP, Eur. Phys. J. C71 (2011) 1607

$$\text{Total } \Delta B = -0.11 \pm 0.04 \pm 0.03$$

Mass difference - QCD

B_s-mixing

1. Lattice

- * ETM 1308.1851
- * FNAL-MILC 1602.03560
- * HPQCD 1907.01025

2. HQET-sum rules: 3-loop + NLO matching:

- *Durham: King, AL, Rauh (Bern) 1904.00940

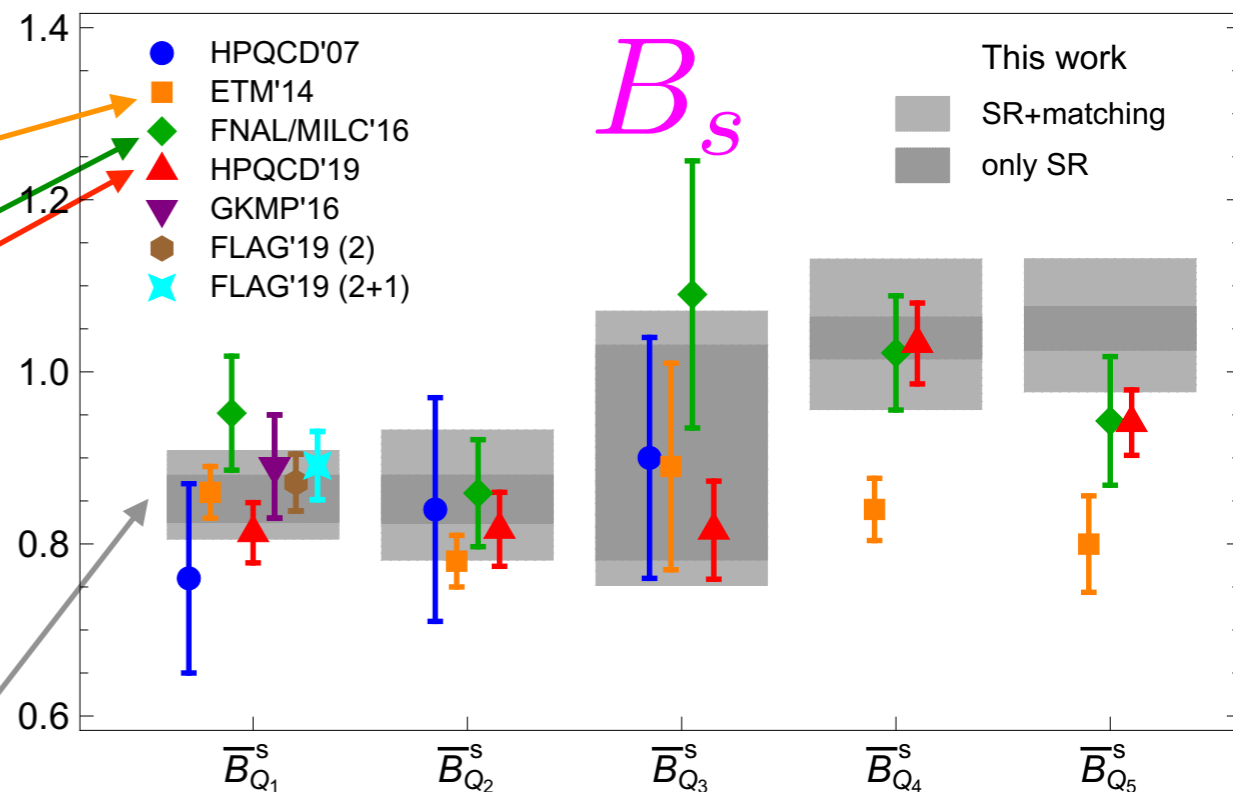

$$r_{\tilde{Q}_1}^{(0)} = 8 - \frac{a_2}{2} - \frac{8\pi^2}{3}$$

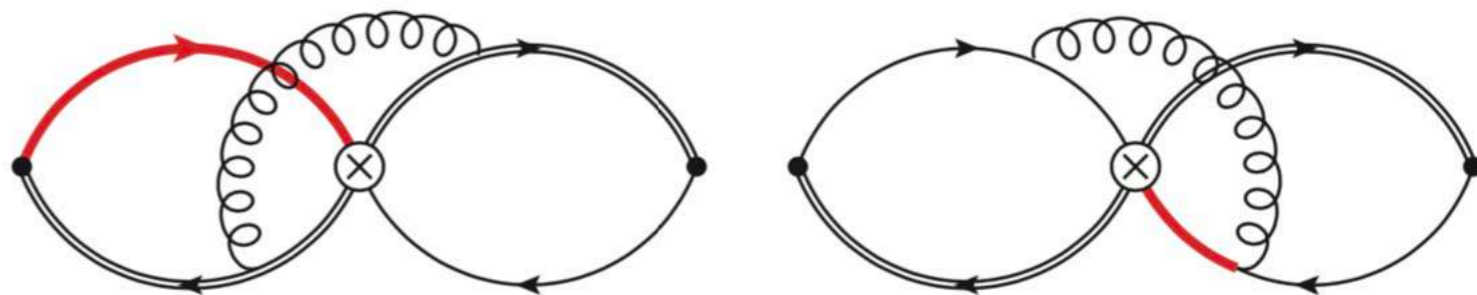

$$r_{\tilde{Q}_1}^{(2)} = \frac{1}{1+x^2} \left[\frac{(1-x)^2 a_2}{4} + \frac{2\pi^2(1-4x+x^2)}{3} + 2x\psi(x) \left(2 + \frac{1+x}{1-x} \ln(x) \right) \right]$$

$$+ \begin{cases} -\frac{2(6+6x-x^2+2x^3)}{3} + 2(2-4x+x^2) \ln(x) - 4(1-x^2) \text{Li}_2(1-1/x), & x \leq 1, \\ -\frac{2(2-x+6x^2+6x^3)}{3x} - 2(1-4x+2x^2) \ln(x) + 4(1-x^2) \text{Li}_2(1-x), & x > 1, \end{cases}$$

Mass difference - QCD

Uncertainties cancel in B_s/B_d

1. Lattice

- * HPQCD 1907.01025
- * RBC/UKQCD 1812.09791
- * FNAL-MILC 1602.03560
- * ETM 1308.1851

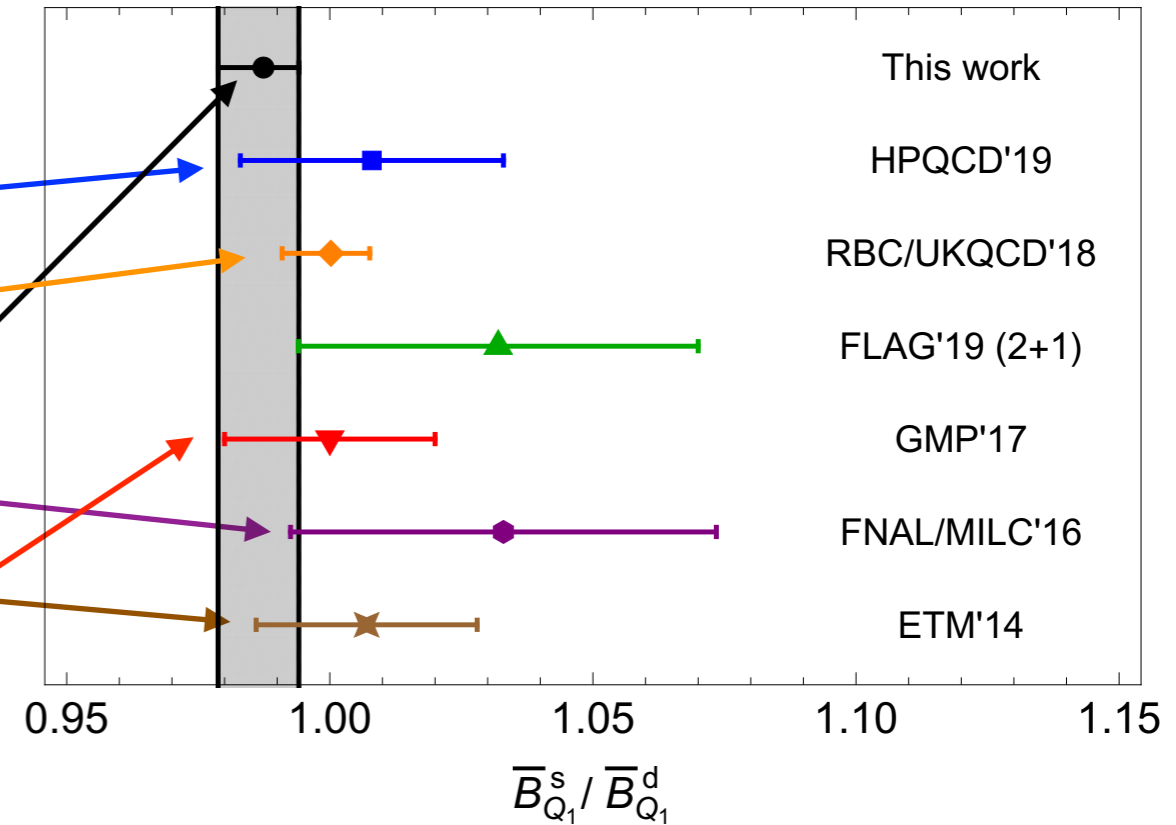

2. HQET-sum rules: 3-loop + NNLO matching:

- * Durham: King, AL, Rauh (Bern) 1904.00940
based on Siegen '16-18, Kirk, AL, Rauh '17

Take decay constants from most recent
2+1+1 lattice evaluation (HPQCD, FNAL-MILC)

New averages of lattice and sum rules

Di Luzio, Kirk, AL, Rauh

1909.11087 JHEP

$$\xi = 1.200^{+0.0054}_{-0.0060}$$

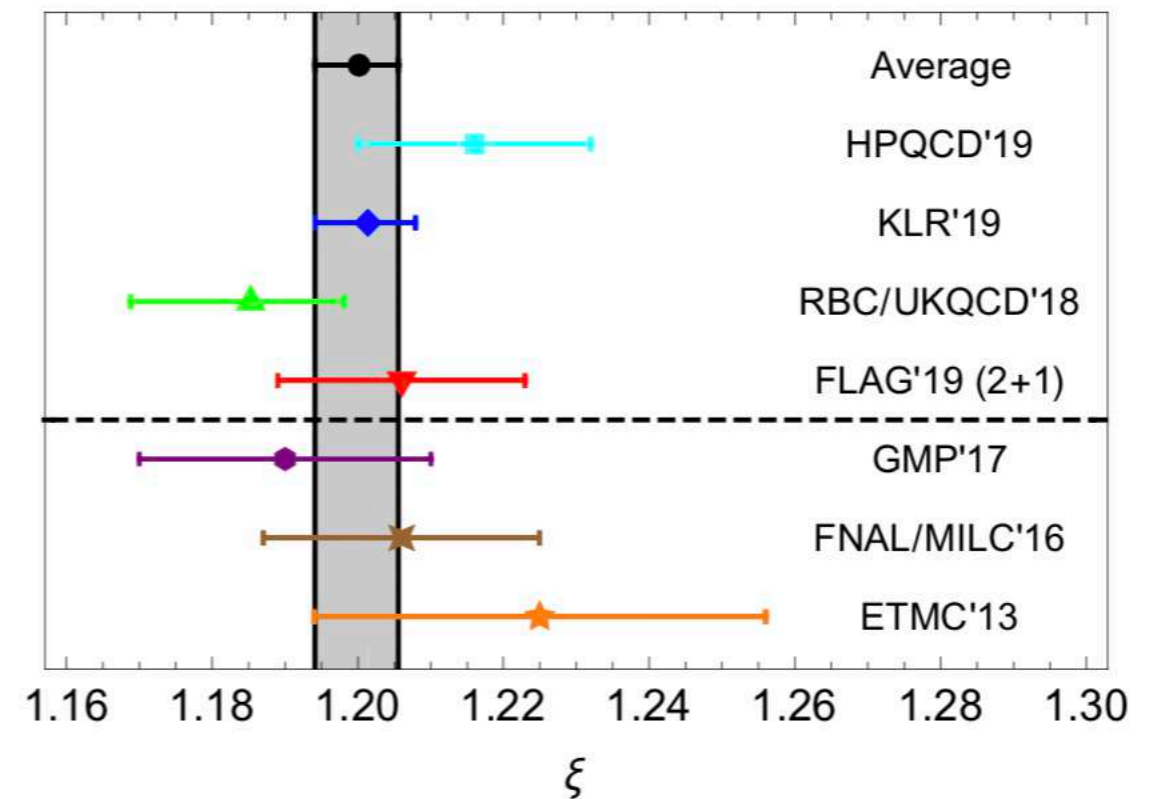

Mass difference - CKM

Comparison with experiment

$$\Delta M_d^{\text{exp}} = (0.5064 \pm 0.0019) \text{ ps}^{-1}, \quad \text{4 per mille}$$

$$\Delta M_s^{\text{exp}} = (17.757 \pm 0.021) \text{ ps}^{-1}. \quad \text{1 per mille}$$

$$\Delta M_d^{\text{Average 2019}} = \left(0.533_{-0.036}^{+0.022}\right) \text{ ps}^{-1} = \left(1.05_{-0.07}^{+0.04}\right) \Delta M_d^{\text{exp}},$$

$$\Delta M_s^{\text{Average 2019}} = \left(18.4_{-1.2}^{+0.7}\right) \text{ ps}^{-1} = \left(1.04_{-0.07}^{+0.04}\right) \Delta M_s^{\text{exp}},$$

Averages of lattice/SR
Di Luzio, Kirk, AL, Rauh
1909.11087 JHEP

- Good agreement with experiment
- Experiment is 15/45 times more precise than theory
- Maybe improvement of theory by a factor of 2 doable in future

Assuming validity of the SM: Extraction of CKM parameter

$$\begin{aligned} |V_{ts}V_{tb}| &= (40.91_{-0.64}^{+0.67}) \cdot 10^{-3} \\ &= \left(40.91_{-0.62}^{+0.65} \Big|_{f_B^2} \pm 0.17 \Big|_{m_t} \pm 0.05 \Big|_{\alpha_s(M_Z)} \pm 0.02 \Big|_{\Delta M_s}\right) \cdot 10^{-3}, \end{aligned}$$

$$|V_{ts}|_{\text{CKMfitter}} = (41.69_{-1.08}^{+0.28}) \cdot 10^{-3}$$

$$|V_{ts}|_{\text{CKMfitter, tree}} = (41.63_{-1.45}^{+0.39}) \cdot 10^{-3}$$

Comparison with CKMfits - competitive precision - slightly smaller than fit

Mass difference - CKM

Very precise prediction of the ratios of mass differences

$$\frac{\Delta M_d}{\Delta M_s} = \left| \frac{V_{td}}{V_{ts}} \right|^2 \frac{1}{\xi^2} \frac{M_{B_d}}{M_{B_s}}$$

$$\left(\frac{\Delta M_d}{\Delta M_s} \right)_{\text{exp}} = 0.0285 \pm 0.0001,$$

$$\left(\frac{\Delta M_d}{\Delta M_s} \right)_{\text{Average}} = 0.0298_{-0.0009}^{+0.0005} = 0.0297_{-0.0003}^{+0.0003} (\text{had.})_{-0.0008}^{+0.0005} (\text{CKM}).$$

1.4 sigma above experiment
Experiment is 7 times more precise than theory

Assuming validity of the SM: Extraction of CKM parameter

$$\begin{aligned} \left| \frac{V_{td}}{V_{ts}} \right| &= 0.2043_{-0.0011}^{+0.0010} \\ &= 0.2043_{-0.0010}^{+0.0009} \Big|_{\xi \pm 0.0003} \Big|_{\Delta M_d \pm 0.0001} \Big|_{\Delta M_s} \end{aligned}$$

vs. $|V_{td}/V_{ts}| = 0.2088_{-0.0030}^{+0.0016}$ [CKMfitter], $|V_{td}/V_{ts}| = 0.2186_{-0.0059}^{+0.0049}$ [UTfit], vs. [CKMfitter, tree]

Slightly below CKMfits - slightly higher precision - 2.3 sigma below tree-level fits

Assuming validity of the SM: Independent determination of m_top

$$\bar{m}_t(\bar{m}_t) = (157_{-6}^{+8}) \text{ GeV} \text{ vs. } \bar{m}_t(\bar{m}_t) = (160_{-4}^{+5}) \text{ GeV, (PDG)}$$

Very good agreement - almost comparable precision

Mass difference - CKM

King, Kirk, AL, Rauh
1911.07856

Within the SM we get

$$V_{tb}V_{ts}^* = -c_{12} \frac{\sqrt{1 - |V_{ub}|^2 - V_{cb}^2}}{1 - |V_{ub}|^2} V_{cb} - s_{12} \frac{1 - |V_{ub}|^2 - V_{cb}^2}{\sqrt{1 - |V_{ub}|^2}} V_{ub} ,$$

$$\frac{V_{ts}^*}{V_{td}^*} = \frac{-c_{12}V_{cb} - s_{12}\sqrt{1 - |V_{ub}|^2 - V_{cb}^2}V_{ub}}{s_{12}V_{cb} - c_{12}\sqrt{1 - |V_{ub}|^2 - V_{cb}^2}V_{ub}}$$

$$s_{12} = \frac{\frac{V_{us}}{V_{ud}}}{\sqrt{1 + \frac{V_{us}^2}{V_{ud}^2}}} , \quad c_{12} = \frac{1}{\sqrt{1 + \frac{V_{us}^2}{V_{ud}^2}}} , \quad V_{ub} = |V_{ub}|e^{-i\gamma} .$$

**Constraints on V_{cb} , V_{ub} , γ ?
Precision????**

Mass difference - CKM

Within the SM we get

King, Kirk, AL, Rauh
1911.07856

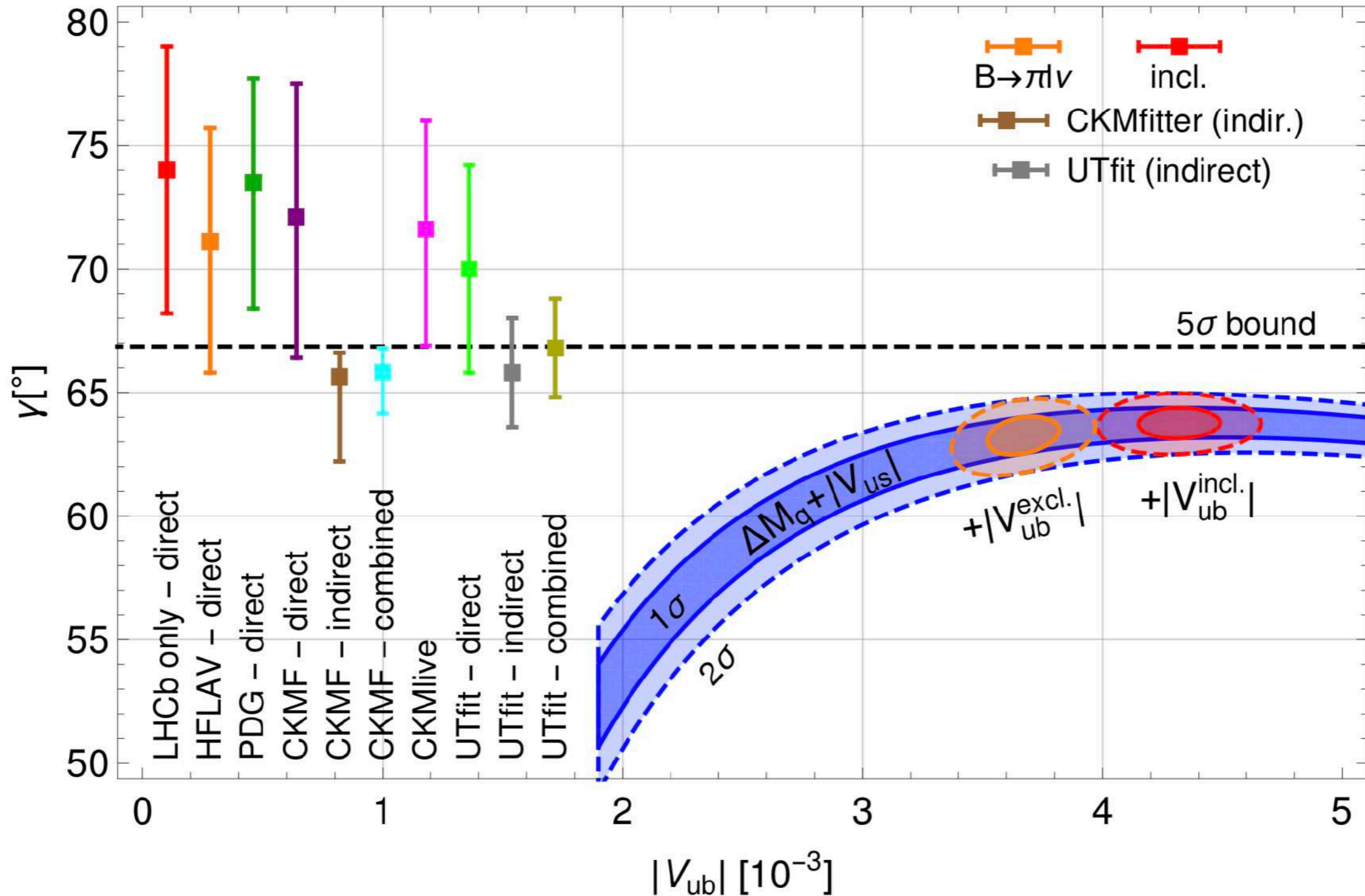

V_{ub} unconstrained, upper limit on gamma?

Mass difference - CKM

Upper limit on gamma?

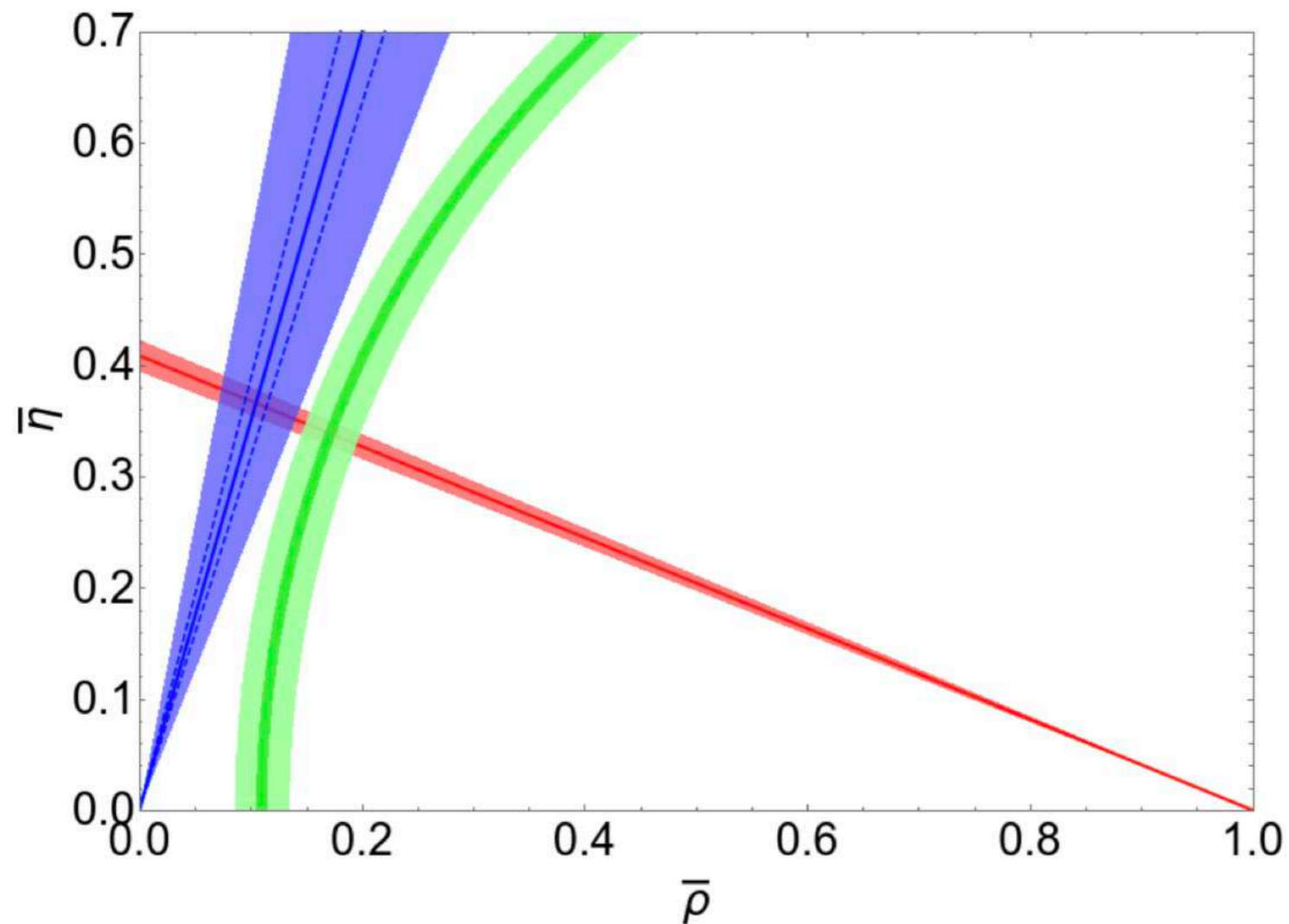

King, Kirk, AL, Rauh
1911.07856

$$\gamma \leq 66.9^\circ$$

[5 σ]

or

- BSM in mixing
- BSM in non-leptonic tree-level decays

Brod, AL, Tetlalmatzi-Xolocotzi 1412.1446, PRD
AL, Tetlalmatzi-Xolocotzi 1912.xxxxx

Mass difference - CKM

Within the SM we get

$$\gamma = (63.4 \pm 0.9)^\circ$$

$$|V_{cb}| = (41.6 \pm 0.7) \cdot 10^{-3}$$

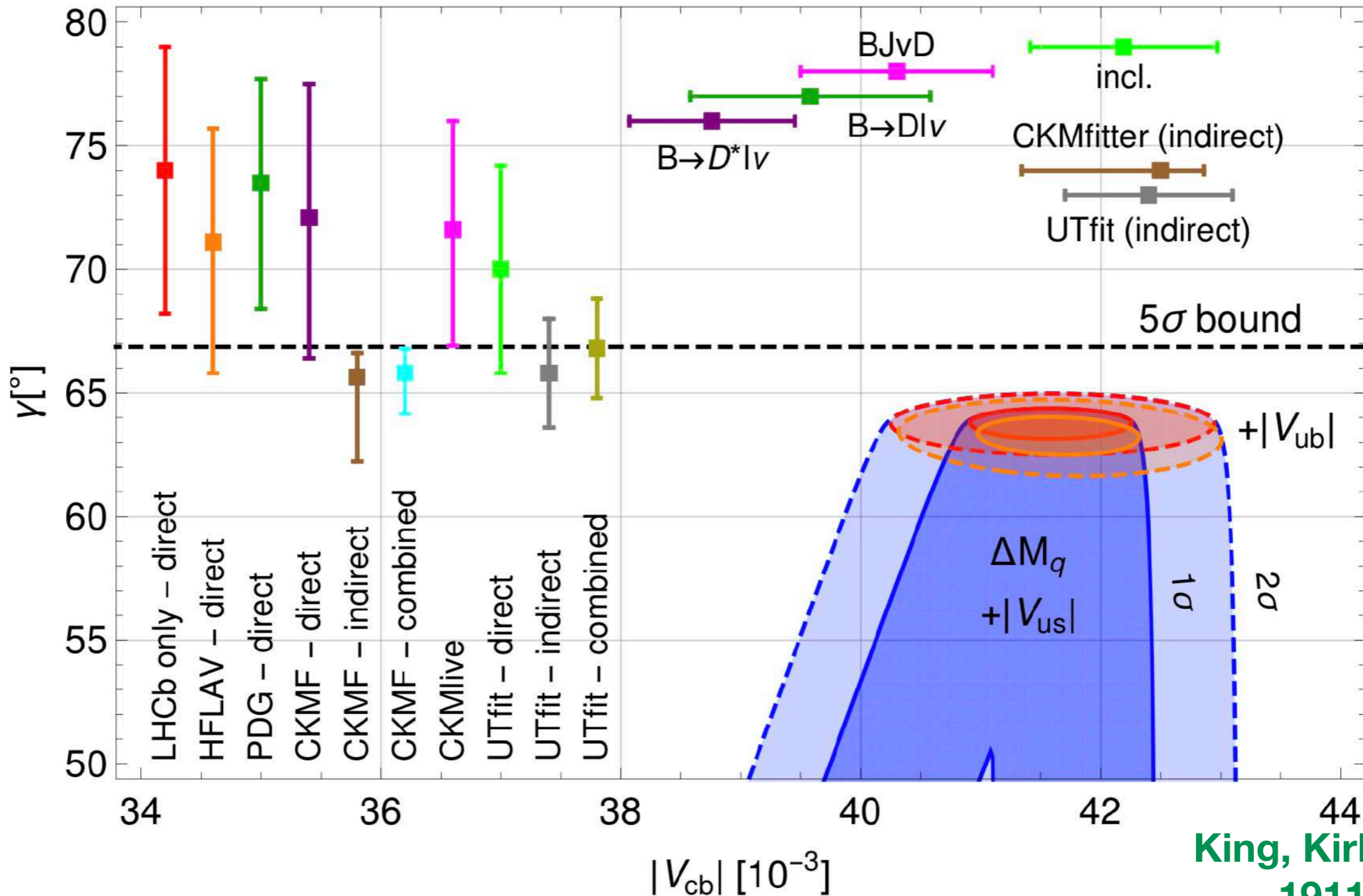

King, Kirk, AL, Rauh
1911.07856

Competitive precision for V_{cb} - favours inclusive value, upper limit on gamma

Mass difference - BSM

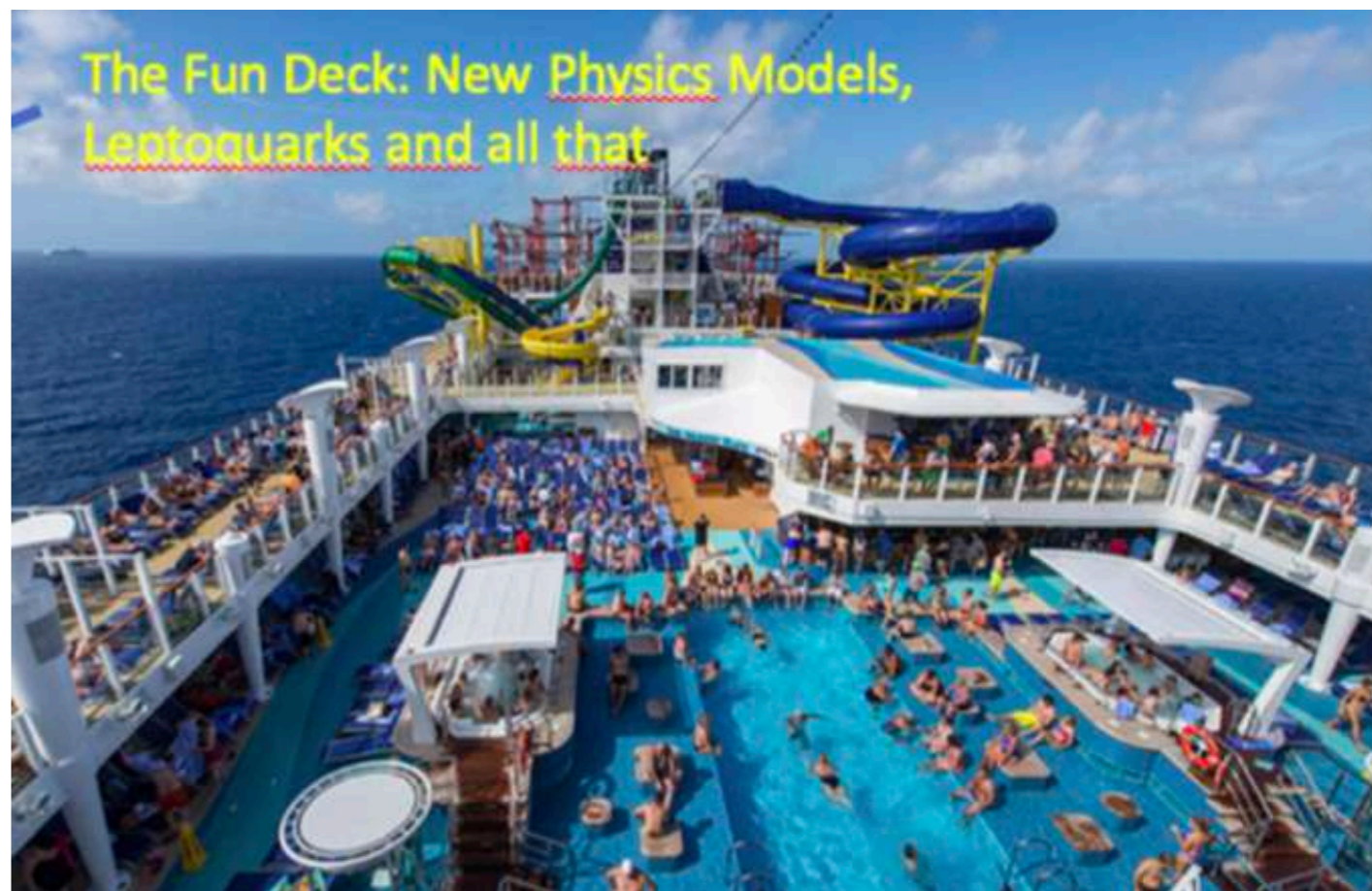
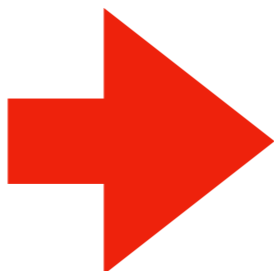

Mass difference - BSM

Flavour anomalies could e.g. be explained by Z' models

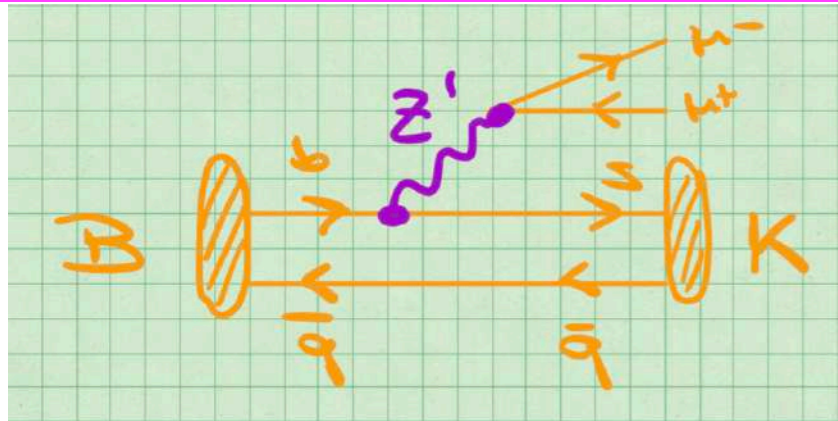

See e.g. Allanach, Davighi, Gripaio, Lohitsiri, Madigan, Meville, You,...

Such a models also modifies the mass difference of neutral mesons

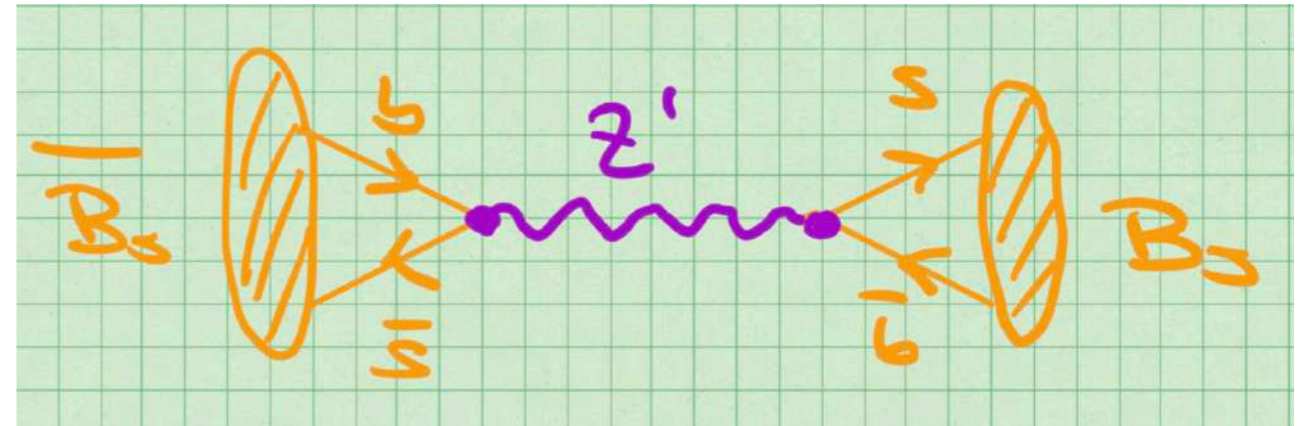

$$\lambda_{\mu\mu}^L = 1$$

Many times the BSM contribution to ΔM_q is positive

Using the large FNAL-MILC value:

One constraint to kill them all! Di Luzio, Kirk, AL

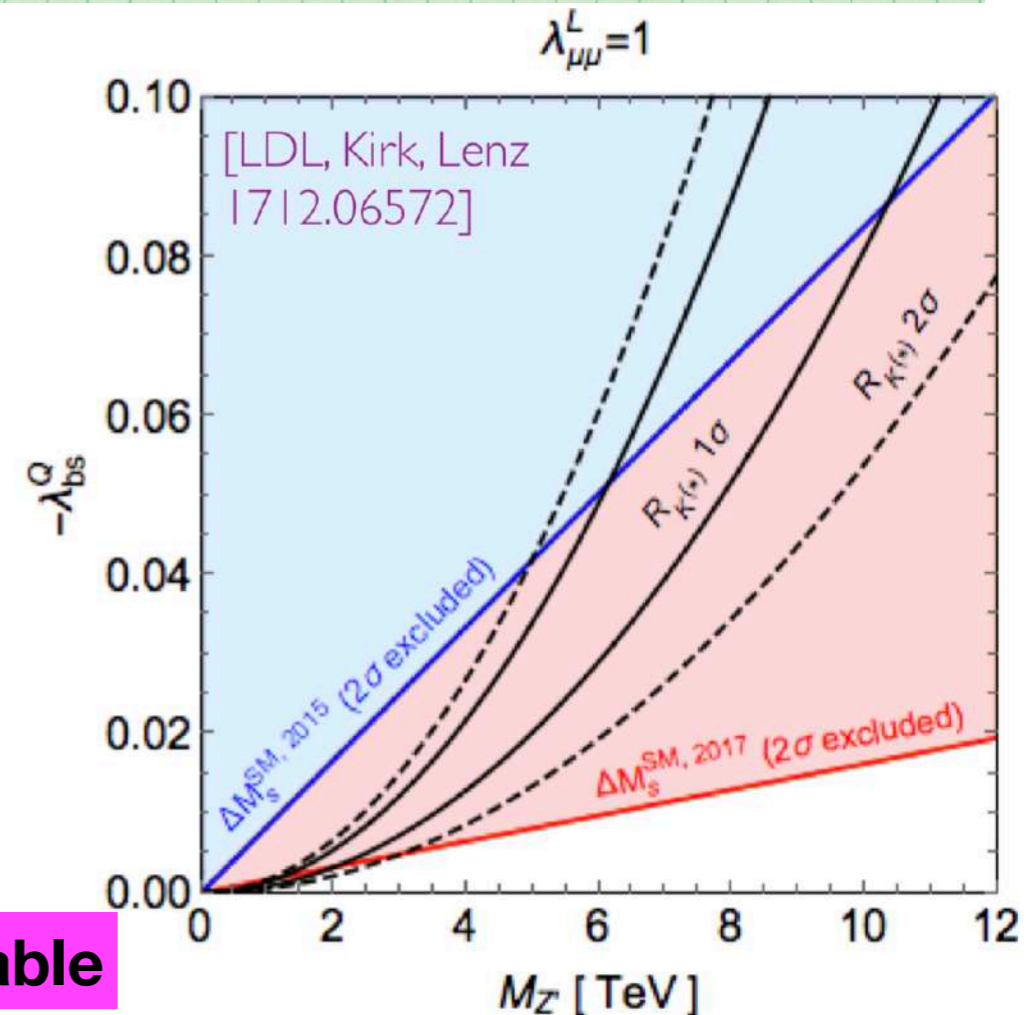

Independent determination of Bs mixing inputs desirable

Mass difference - BSM

Di Luzio, Kirk, AL, Rauh
1909.11087 JHEP

Update: use new average of non-perturbative results

$$\lambda_{22}^L = 1$$

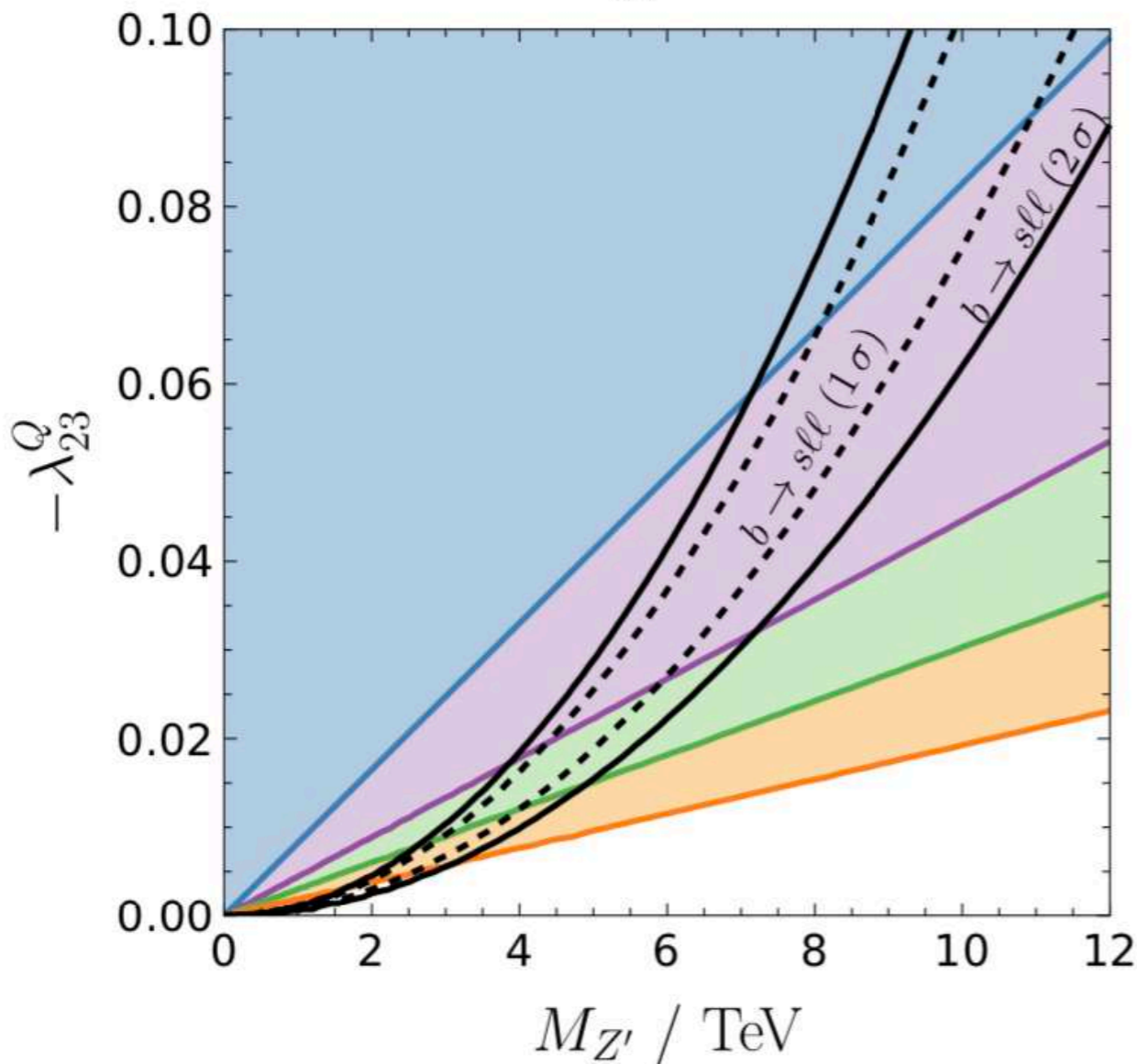

$$\lambda_{22}^L = \sqrt{4\pi}$$

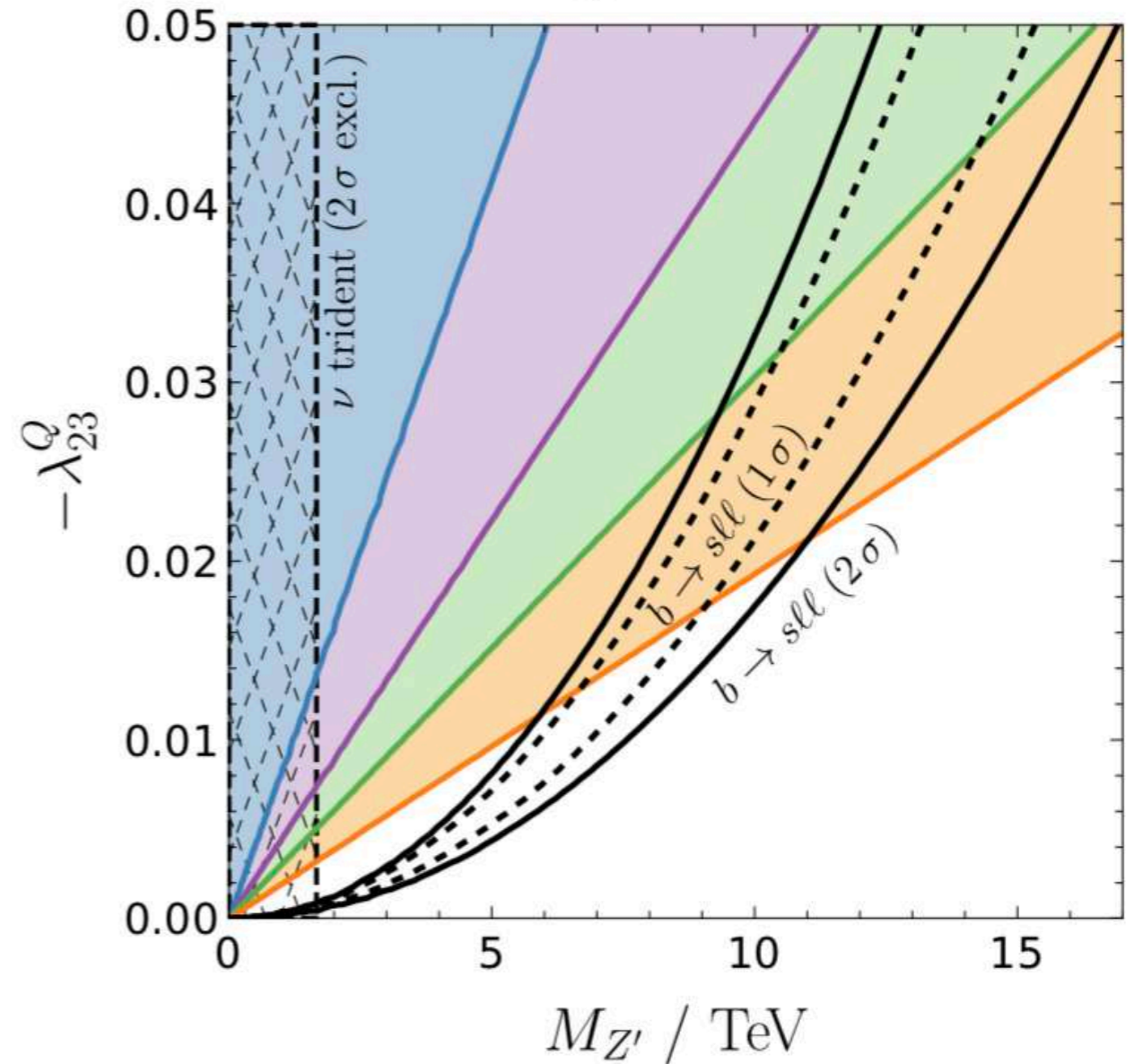

FLAG '13 (2 σ excl.) Avg. '19 (2 σ excl.) FLAG '19 (2 σ excl.) Future '25 (2 σ excl.)

2% non-pert./1% V_{cb}

Mass difference - BSM

Future projections

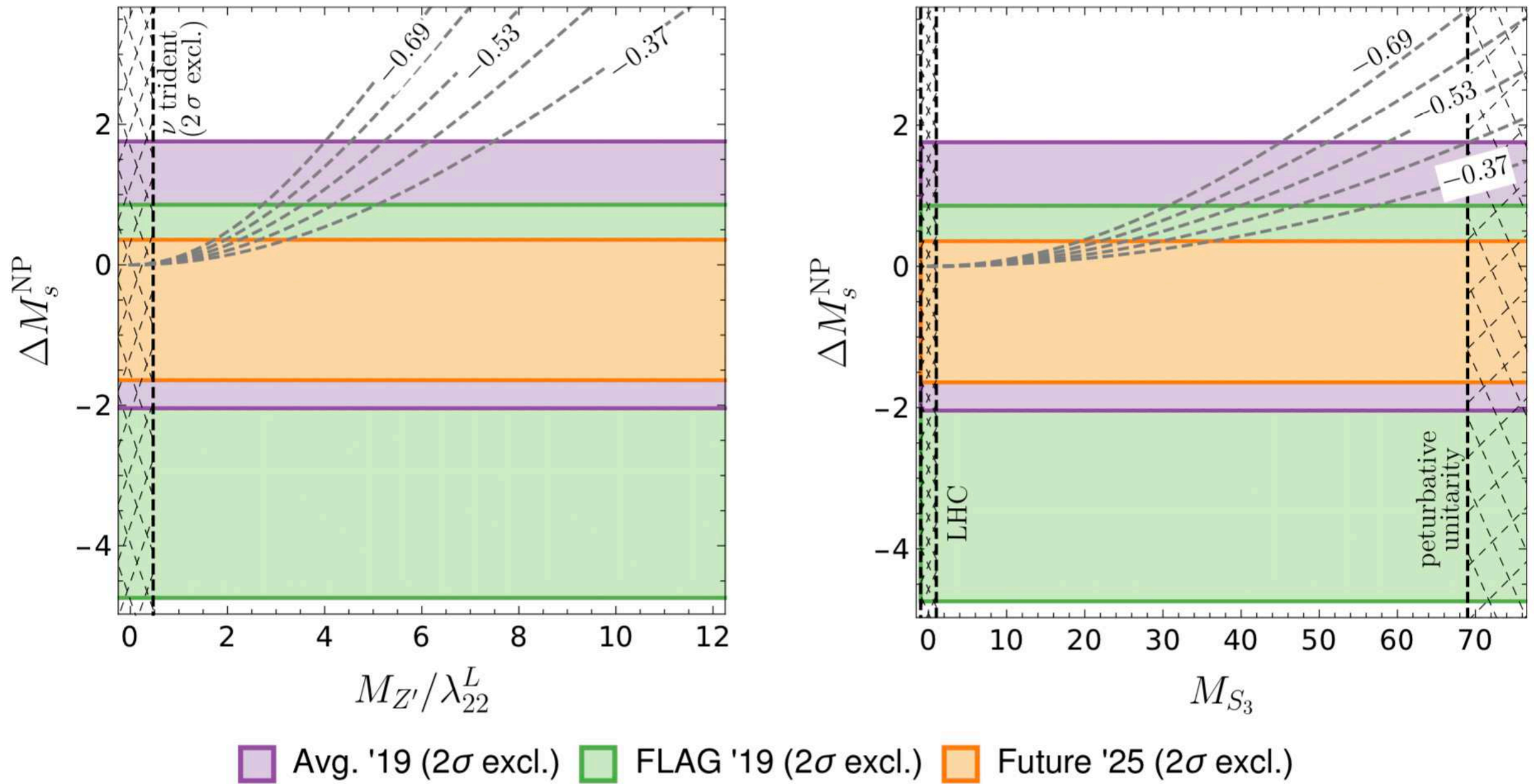

Outline

- **Motivation for Flavour Physics**
 - **Understanding of QCD**
 - **Determination of SM parameter**
 - **CP violation**
 - **Search for new physics**
- **Mass differences of neutral mesons**
 - **Understanding of QCD**
 - **Determination of CKM parameter**
 - **Search for new physics**
- **Decay rate difference/Lifetimes**
 - **Understanding of QCD**
 - **Search for new physics**
 - **CP violation**

LIFETIMES

BEAUTY LIFETIMES: Precision test of HQE convergence
Test of Higher orders in the HQE
Search for invisible decay channels in Bs or Bd

DECAY RATE DIFFERENCES/SEMI-LEPTONIC CP ASYMMETRIES:
Test of quark hadron duality
Precision test of HQE convergence
BSM searches/CP violation

CHARM LIFETIMES: Test of convergence of HQE
Implications for ΔA_{CP} - QCD vs. **BSM**

Heavy Quark Expansion

Shifman, Voloshin, Khoze; Bigi, Uraltsev, Vainshtein; (1983 -'92)

In more detail we get

$$\Gamma = \Gamma_0 \langle O_{D=3} \rangle + \Gamma_2 \frac{\langle O_{D=5} \rangle}{m_Q^2} + \tilde{\Gamma}_3 \frac{\langle \tilde{O}_{D=6} \rangle}{m_Q^3} + \dots$$
$$+ 16\pi^2 \left[\Gamma_3 \frac{\langle O_{D=6} \rangle}{m_Q^3} + \Gamma_4 \frac{\langle O_{D=7} \rangle}{m_Q^4} + \Gamma_5 \frac{\langle O_{D=8} \rangle}{m_Q^5} + \dots \right]$$

Working definition of QHDV = deviation from the above framework

- Γ_0 : free quark decay
- Perturbative corrections in Γ_i
- Non-perturbative corrections in matrix elements
- There are no $1/m_Q$ corrections
- Γ_2 : kinetic and chromomagnetic term
- $\tilde{\Gamma}_3$: Spin-orbit and Darwin term
- Γ_3 : Spector effects, 1-loop instead of 2-loops
- $\Gamma_4 \Gamma_5$: $1/m_Q$ corrections to Γ_3

LIFETIMES



Mark Williams
@QuarkWilliams



Following

How much can I trust theoretical predictions? Finally the star-based rating system I've been waiting for! Thanks

@alexlenz42! arxiv.org/pdf/1809.09452...

A + for each independent calculation
At most ++
At most +++ for <>: 2 lattice, 1 sum rule
Punishment: A - - for no <Q6>
A 0 for quark model et al for <Q6>

<i>Obs.</i>	$\Gamma_3^{(0)}$	$\Gamma_3^{(1)}$	$\Gamma_3^{(2)}$	$\langle O^{d=6} \rangle$	$\Gamma_4^{(0)}$	$\Gamma_4^{(1)}$	$\langle O^{d=7} \rangle$	Σ
$\tau(B^+)/\tau(B_d)$	++	++	0	+	++	0	0	** (7+)
$\tau(B_s)/\tau(B_d)$	++	++	0	$\frac{+}{2}$	++	0	0	** (6.5+)
$\tau(\Lambda_b)/\tau(B_d)$	++	$\frac{+}{2}$	0	$\frac{+}{2}$	+	0	0	** (4+)
$\tau(b - baryon)/\tau(B_d)$	++	0	0	0	+	0	0	* (3+)
$\tau(B_c)$	+	0	0	+	0	0	0	* (2+)
$\tau(D^+)/\tau(D^0)$	++	++	0	+	++	0	0	** (7+)
$\tau(D_s^+)/\tau(D^0)$	++	++	0	$\frac{+}{2}$	++	0	0	** (6.5+)
$\tau(c - baryon)/\tau(D^0)$	++	0	0	0	+	0	0	* (3+)

Hai-Yang Cheng 1807.00916

****: 12-15

*** 8 -11.5

** : 4-7.5

*: 2-3.5

BEAUTY LIFETIMES

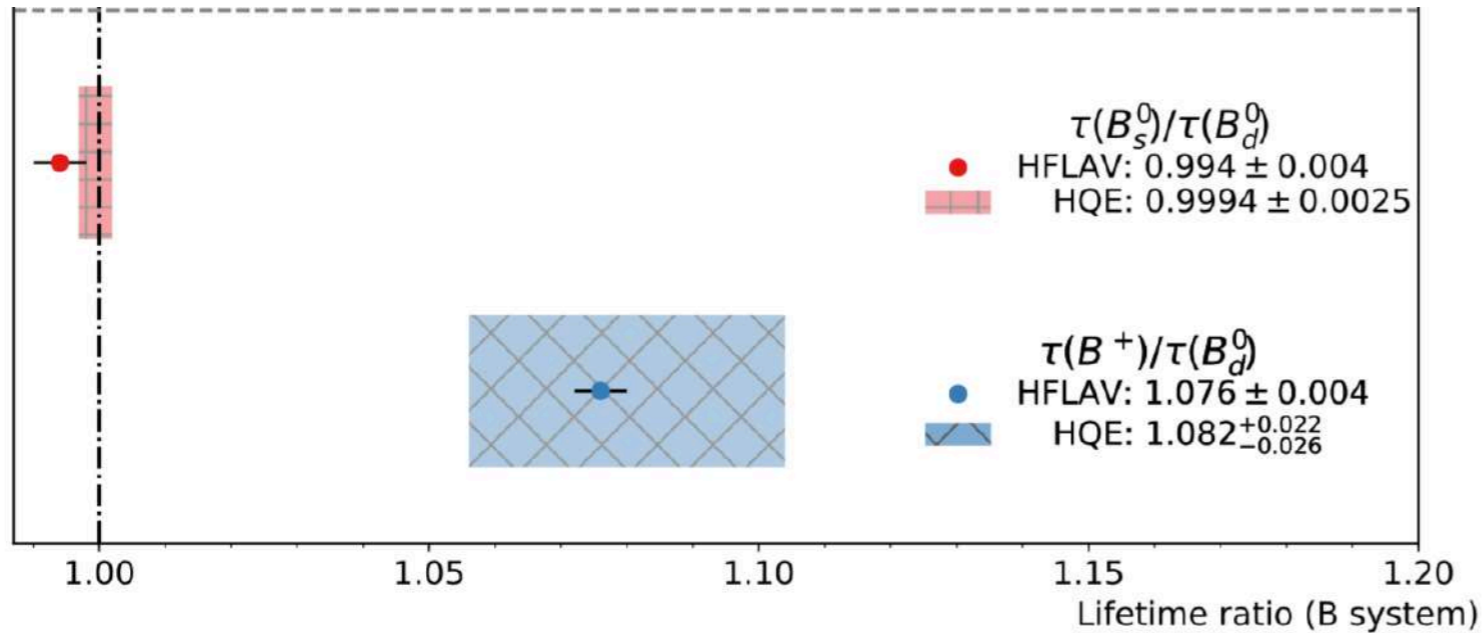

Dim 6 matrix elements determined with 3loop HQET sum rules
 Lattice confirmation very welcome

Kirk, AL, Rauh 1711.02100

Amazing cancellations in the Bs/Bd system

$$\frac{\tau(B_s)}{\tau(B_d)} = \frac{\Gamma_b + \delta\Gamma_{B_d}}{\Gamma_b + \delta\Gamma_{B_s}} = 1 + (\delta\Gamma_{B_d} - \delta\Gamma_{B_s}) \tau(B_s).$$

Leads to an unexpected sensitivity to

- higher orders in the HQE

$$\Gamma = \Gamma_0 \langle O_{D=3} \rangle + \Gamma_2 \frac{\langle O_{D=5} \rangle}{m_Q^2} + \tilde{\Gamma}_3 \frac{\langle \tilde{O}_{D=6} \rangle}{m_Q^3} + \dots$$

in progress

$$+ 16\pi^2 \left[\Gamma_3 \frac{\langle O_{D=6} \rangle}{m_Q^3} + \Gamma_4 \frac{\langle O_{D=7} \rangle}{m_Q^4} + \Gamma_5 \frac{\langle O_{D=8} \rangle}{m_Q^5} + \dots \right]$$

- invisible Bs decays at the permille level, e.g.

$$Br(B_s \rightarrow \tau^+ \tau^-) < 6.8 \cdot 10^{-3} \text{ LHCb}$$

$$Br(B_d \rightarrow \tau^+ \tau^-) < 2.1 \cdot 10^{-3} \text{ LHCb}$$

$$\frac{\tau(B_s)}{\tau(B_d)} \approx 1 + \delta\Gamma_{B_d}^{\text{SM}} \tau(B_s) - \delta\Gamma_{B_s}^{\text{SM}} \tau(B_s) + Br(B_d \rightarrow X)^{\text{BSM}} - Br(B_s \rightarrow Y)^{\text{BSM}},$$

BEAUTY LIFETIMES

Motivation

★ Current experimental status:

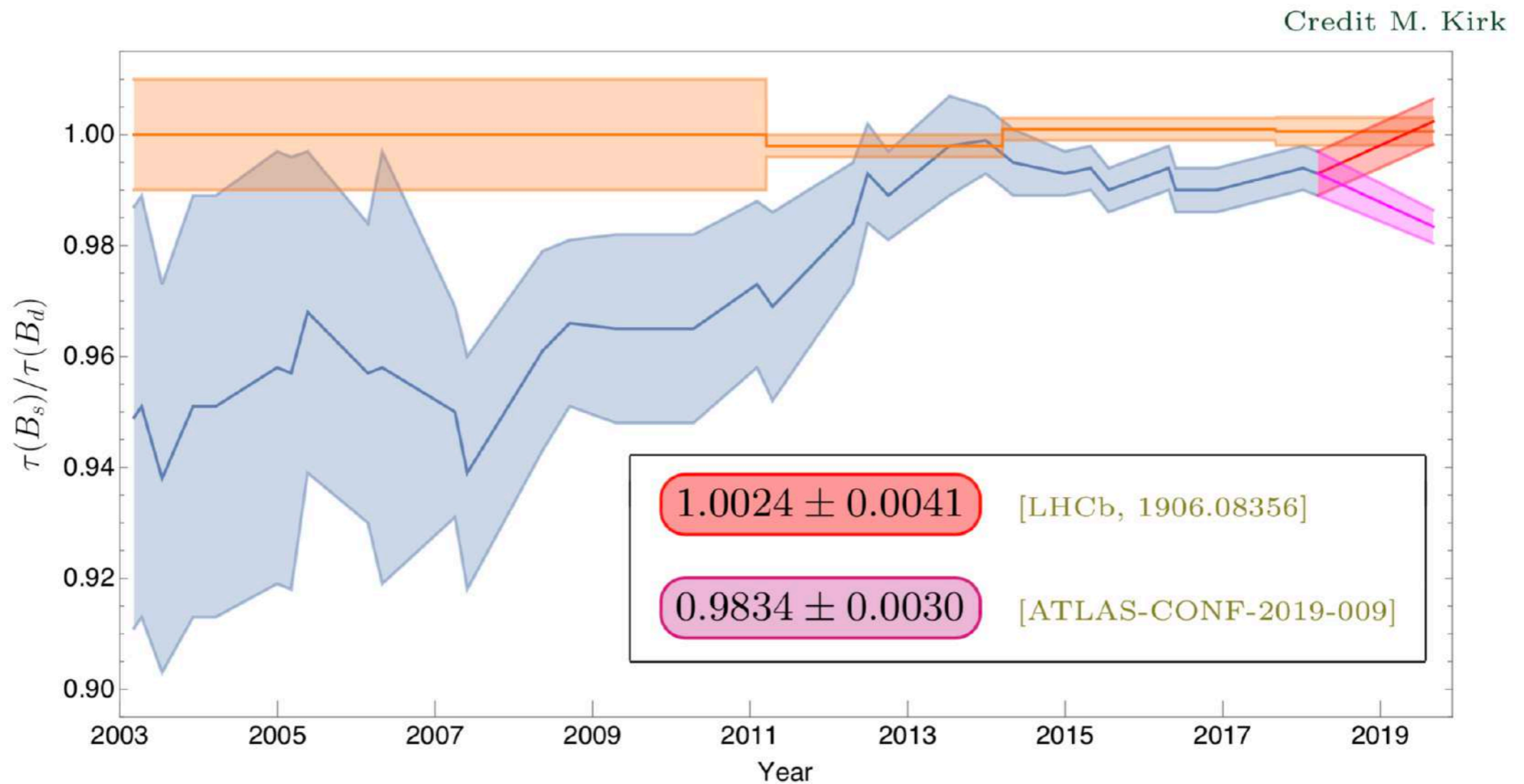

Decay rate difference $\Delta\Gamma_s$

Calculation is more difficult than mass difference - use Heavy Quark Expansion

$$\Gamma_{12} = \frac{\Lambda^3}{m_b^3}\Gamma_3 + \frac{\Lambda^4}{m_b^4}\Gamma_4 + \dots$$

Each term can be split up into a perturbative part and non-perturbative matrix elements

$$\Gamma_i = \left[\Gamma_i^{(0)} + \frac{\alpha_S}{4\pi}\Gamma_i^{(1)} + \frac{\alpha_S^2}{(4\pi)^2}\Gamma_i^{(2)} + \dots, \right] \langle O^{d=i+3} \rangle$$

$$R_2 = \frac{1}{m_b^2}(\bar{b}^\alpha \overleftarrow{D}_\rho \gamma^\mu (1 - \gamma^5) D^\rho s^\alpha)(\bar{b}^\beta \gamma_\mu (1 - \gamma^5) s^\beta)$$

$$R_3 = \frac{1}{m_b^2}(\bar{b}^\alpha \overleftarrow{D}_\rho (1 - \gamma^5) D^\rho s^\alpha)(\bar{b}^\beta (1 - \gamma^5) s^\beta)$$

Status of theory predictions

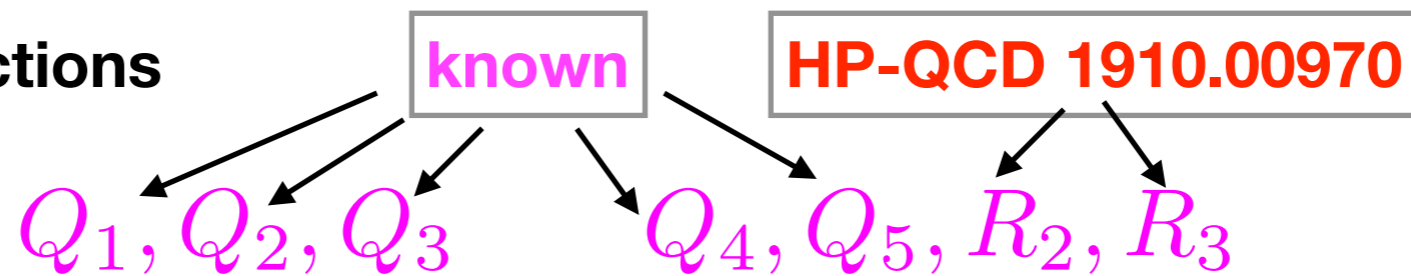

<i>Obs.</i>	$\Gamma_3^{(0)}$	$\Gamma_3^{(1)}$	$\Gamma_3^{(2)}$	$\langle O^{d=6} \rangle$	$\Gamma_4^{(0)}$	$\Gamma_4^{(1)}$	$\langle O^{d=7} \rangle$	Σ
Γ_{12}^s	++	++	$\frac{\pm}{2}$	+++	++	0	+	10.5 + (***)
Γ_{12}^d	++	++	0	+++	++	0	+	10 + (***)

Decay rate difference $\Delta\Gamma_s$

Relation to experiment

$$\Re\left(\frac{\Gamma_{12}^q}{M_{12}^q}\right) = -\frac{\Delta\Gamma_s}{\Delta M_q}$$

$$\Im\left(\frac{\Gamma_{12}^q}{M_{12}^q}\right) = a_{sl}^q$$

- Decay constants cancel completely
- Bag parameter cancel largely

SM predictions

$$\Delta\Gamma_s^{\text{SM} 2019} = (0.091 \pm 0.013) \text{ ps}^{-1}$$

$$\Delta\Gamma_s^{\text{HFLAV} 2019} = (0.088 \pm 0.006) \text{ ps}^{-1}$$

- Good agreement
- Experiment about 2 times more precise

$$\Delta\Gamma_d^{\text{SM} 2019} = (2.6 \pm 0.4) \cdot 10^{-3} \text{ ps}^{-1}$$

$$\Delta\Gamma_d^{\text{HFLAV} 2019} = (-1.3 \pm 6.6) \cdot 10^{-3} \text{ ps}^{-1}$$

- Might solve the D0 di-muon asymmetry
- Experimental number needed

- Strong test of HQE
- Violation of Quark hadron duality must be small

Decay rate difference $\Delta\Gamma_s$

$\Delta\Gamma_s^{\text{SM}}$	this work	ABL 2015	LN 2011	LN 2006
Central Value	0.091 ps ⁻¹	0.088 ps ⁻¹	0.087 ps ⁻¹	0.096 ps ⁻¹
$\delta(B_{\tilde{R}_2})$	10.9%	14.8%	17.2%	15.7%
$\delta(\mu)$	6.6%	8.4%	7.8%	13.7%
$\delta(V_{cb})$	3.4%	4.9%	3.4%	4.9%
$\delta(B_{R_0})$	3.2%	2.1%	3.4%	3.0%
$\delta(f_{B_s}\sqrt{B_1})$	3.1%	13.9%	13.5%	34.0%
$\delta(B_3)$	2.2%	2.1%	4.8%	3.1%
$\delta(\bar{z})$	0.9%	1.1%	1.5%	1.9%
$\delta(m_b)$	0.9%	0.8%	0.1%	1.0%
$\delta(B_{R_3})$	0.5%	0.2%	0.2%	— — —
$\delta(B_{\tilde{R}_3})$	-	0.6%	0.5%	— — —
$\delta(m_s)$	0.3%	0.1%	1.0%	1.0%
$\delta(B_{\tilde{R}_1})$	0.2%	0.7%	1.9%	— — —
$\delta(\alpha_s)$	0.1%	0.1%	0.4%	0.1%
$\delta(\gamma)$	0.1%	0.1%	0.3%	1.0%
$\delta(B_{R_1})$	0.1%	0.5%	0.8%	— — —
$\delta(V_{ub}/V_{cb})$	0.1%	0.1%	0.2%	0.5%
$\delta(\bar{m}_t(\bar{m}_t))$	0.0%	0.0%	0.0%	0.0%
$\sum \delta$	14.1%	22.8%	24.5%	40.5%

Thanks Matthew!

**First non-pert.
Determination
HP-QCD
1910.00970**

Decay rate difference $\Delta\Gamma_s$

Relation to experiment

$$\Re\left(\frac{\Gamma_{12}^q}{M_{12}^q}\right) = -\frac{\Delta\Gamma_s}{\Delta M_q}$$

$$\Im\left(\frac{\Gamma_{12}^q}{M_{12}^q}\right) = a_{sl}^q$$

- Decay constants cancel completely
- Bag parameter cancel largely

SM predictions

$$\Delta\Gamma_s^{\text{SM 2019}} = (0.091 \pm 0.013) \text{ ps}^{-1}$$

$$\Delta\Gamma_s^{\text{HFLAV 2019}} = (0.088 \pm 0.006) \text{ ps}^{-1}$$

$$\Delta\Gamma_d^{\text{SM 2019}} = (2.6 \pm 0.4) \cdot 10^{-3} \text{ ps}^{-1}$$

$$\Delta\Gamma_d^{\text{HFLAV 2019}} = (-1.3 \pm 6.6) \cdot 10^{-3} \text{ ps}^{-1}$$

- Strong test of HQI
- Violation of Quark

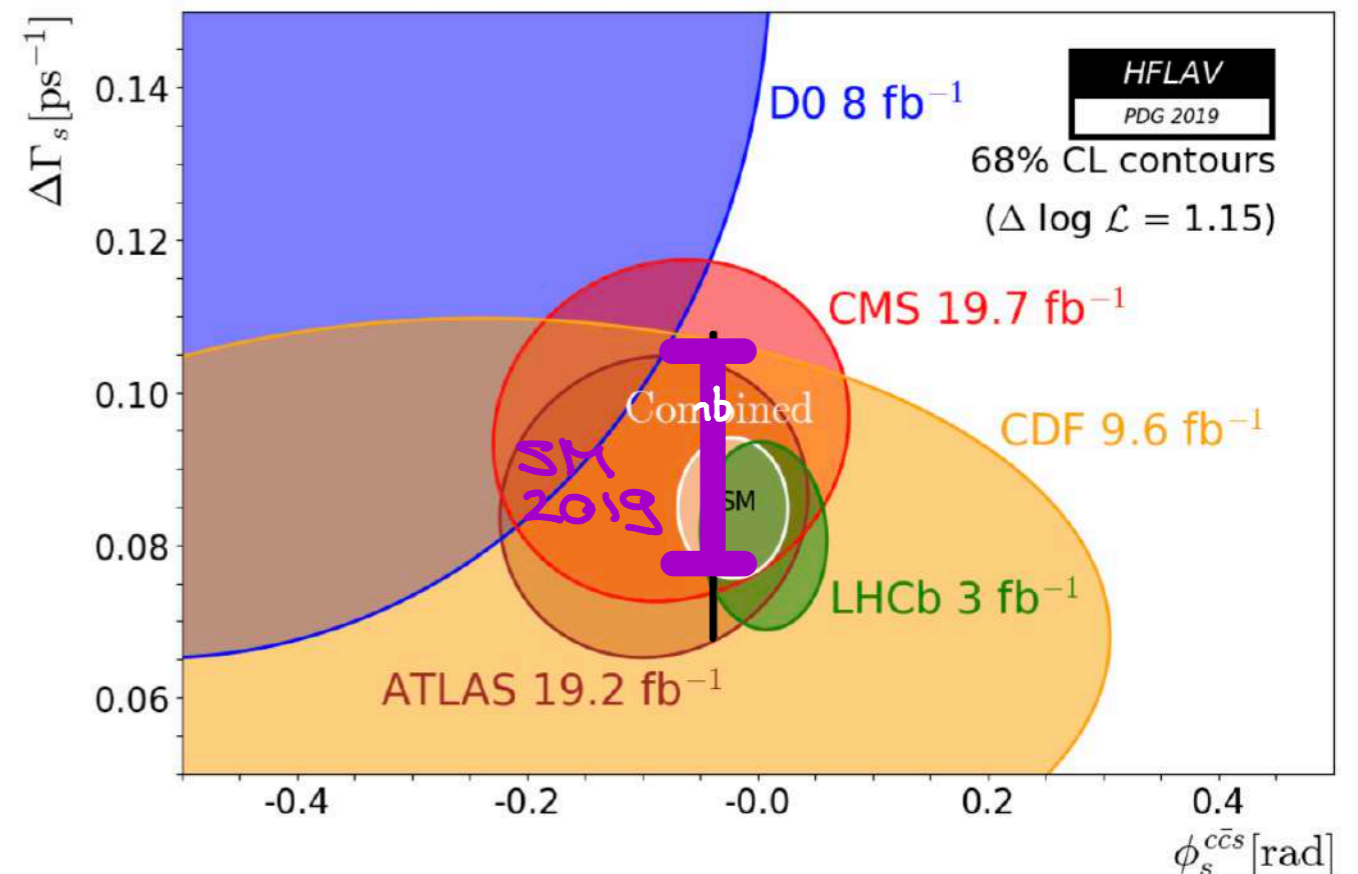

Semi-leptonic CP asymmetries

Relation to experiment

$$\Re \left(\frac{\Gamma_{12}^q}{M_{12}^q} \right) = - \frac{\Delta\Gamma_s}{\Delta M_q}$$
$$\Im \left(\frac{\Gamma_{12}^q}{M_{12}^q} \right) = a_{sl}^q$$

CP violating!

- Decay constants cancel completely
- Bag parameter cancel largely

SM predictions

$$a_{fs}^{s, \text{SM 2019}} = (2.06 \pm 0.18) \cdot 10^{-5}$$

$$a_{fs}^{s, \text{HFLAV 2019}} = (-60 \pm 280) \cdot 10^{-5}$$

$$a_{fs}^{d, \text{SM 2019}} = -(4.73 \pm 0.42) \cdot 10^{-4}$$

$$a_{fs}^{d, \text{HFLAV 2019}} = (-21 \pm 17) \cdot 10^{-4}$$

- Very sensitive to BSM effects!
- Experimental number needed

Semi-leptonic CP asymmetries

Relation to experiment

$$\Re \left(\frac{\Gamma_{12}^q}{M_{12}^q} \right) = - \frac{\Delta\Gamma_s}{\Delta M_q}$$

$$\Im \left(\frac{\Gamma_{12}^q}{M_{12}^q} \right) = a_{sl}^q$$

CP violating!

- Decay constants cancel completely
- Bag parameter cancel largely

SM predictions

$$a_{fs}^{s, \text{SM 2019}} = (2.06 \pm 0.18) \cdot 10^{-5}$$

$$a_{fs}^{d, \text{SM 2019}} = -(4.73 \pm 0.42) \cdot 10^{-4}$$

- Very sensitive to BSM effects!
- Experimental number needed

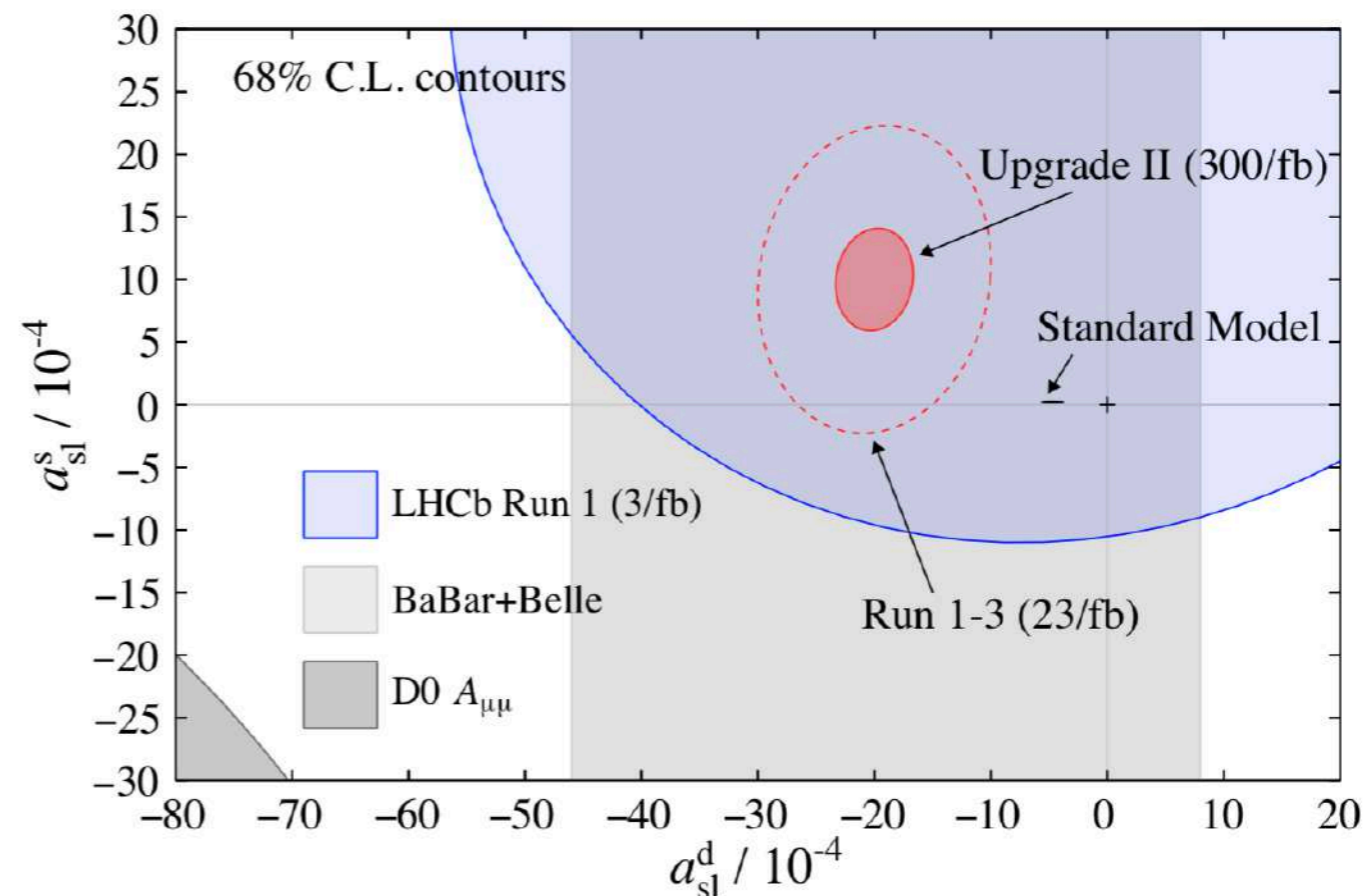

Charm Lifetimes

$\Lambda/m_c \approx 3\Lambda/m_b$ - could still give some reasonable estimates!

Look in systems without GIM cancellation: D-lifetimes

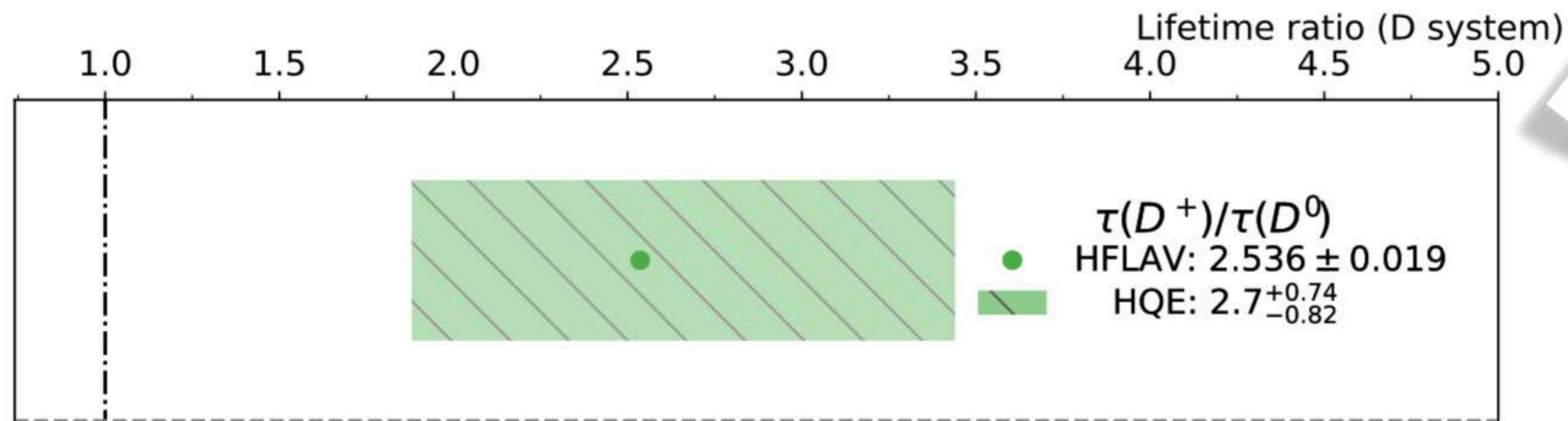

NEW
3-loop
sum rules

$$\frac{\tau(D^+)}{\tau(D^0)} = 2.7 = 1 + 16\pi^2 (0.25)^3 (1 - 0.34)$$

Kirk, AL, Rauh 1711.02100

pert. NLO-QCD:

AL, Rauh 1305.3588

Expansion parameter for HQE in charm = 0.3
 not a back of envelope statement, but real calculations

d=6 calculated with sum rules
lattice confirmation urgently needed

d=7 estimated in vacuum insertion approximation
do sum rule/lattice

Charm Lifetimes -> Delta A_CP

Theory predictions in the charm sector have a terrible reputation

- Delta I = 1/2 rule in the Kaon sector
- Charm mixing is 4 orders of magnitude off

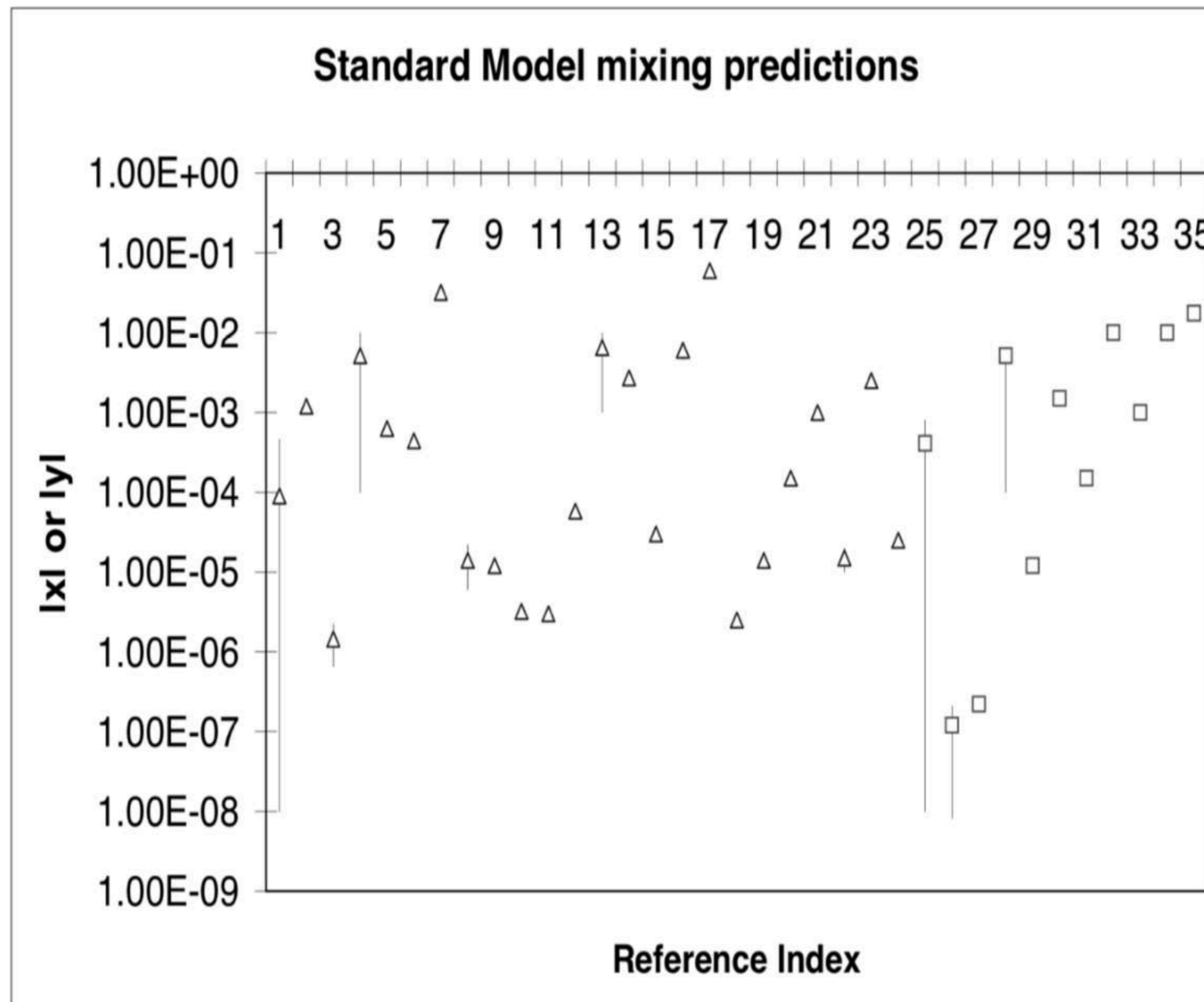

Charm Lifetimes -> Delta A_CP

Theory predictions in the charm sector have a terrible reputation

- Delta I = 1/2 rule in the Kaon sector
- Charm mixing is 4 orders of magnitude off

BUT:

- Lattice: Delta I=1/2 in Kaons not due to large penguins
- Failure of mixing predictions due to GIM cancellation (20% deviation sufficient to explain experiment)
- Lifetimes indicate an expansion parameter in the range 0.3



Maybe not unreasonable to try b-theory tools for Delta A_CP

ΔA_{CP} within the Standard Model and beyond

Mikael Chala, Alexander Lenz, Aleksey V. Rusov and Jakub Scholtz

Institute for Particle Physics Phenomenology, Durham University,
DH1 3LE Durham, U.K.

E-mail: mikael.chala@durham.ac.uk, alexander.lenz@durham.ac.uk,
aleksey.rusov@durham.ac.uk, jakubscholtz@durham.ac.uk

ABSTRACT: In light of the recent LHCb observation of CP violation in the charm sector, we review standard model (SM) predictions in the charm sector and in particular for ΔA_{CP} . We get as an upper bound in the SM $|\Delta A_{CP}^{SM}| \leq 3.6 \times 10^{-4}$, which can be compared to the measurement of $\Delta A_{CP}^{LHCb2019} = (-15.4 \pm 2.9) \times 10^{-4}$. We discuss resolving this tension within an extension of the SM that includes a flavour violating Z' that couples only to $s\bar{s}$ and $\bar{c}u$. We show that for masses below 80 GeV and flavour violating coupling of the order of 10^{-4} , this model can successfully resolve the tension and avoid constraints from dijet searches. $D^0 - \bar{D}^0$ mixing and measurements of the Z width.

JHEP07(2019)161

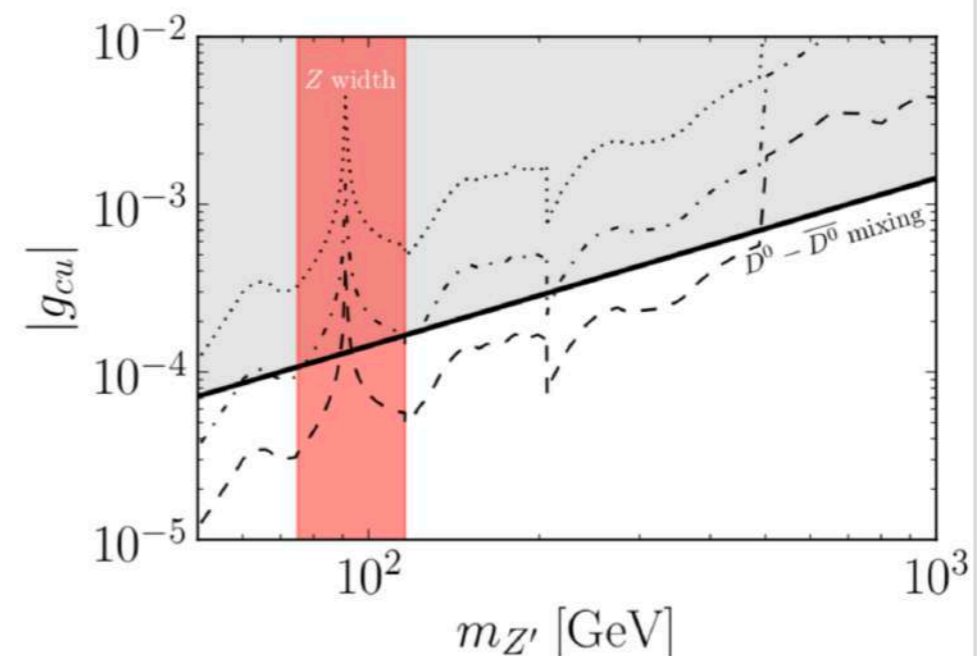

Conclusion

- 1) Severe theoretical progress in mixing and lifetime predictions in recent years
- 2) Theory prediction for mass differences agree with experiment - weaker bounds on BSM models
- 3) For some quantities sum rules are highly competitive to lattice, e.g. Bag parameter for mixing
- 4) Theory uncertainties can still be reduced significantly with current technology
- 5) BSM consequences
 - BSM effects in box diagrams
 - Problems in CKM gamma \rightarrow NP in tree level?
 - $b \rightarrow s \mu \mu$ anomalies $\rightarrow Z', LQ$
 - $b \rightarrow s \tau \tau$ or $b \rightarrow s$ invisible - DM?
 - Convergence of the HQE in charm $\rightarrow \Delta A_{CP}: Z'?$
 - New CP violation effects
- 6) A lot of work has still to be done - but it can be done!

